

LOSSNAY

HANDBOOK

MODELS

LGH-15RVX-E

LGH-25RVX-E

LGH-35RVX-E

LGH-50RVX-E

LGH-65RVX-E

LGH-80RVX-E

LGH-100RVX-E

LGH-150RVX-E

LGH-200RVX-E

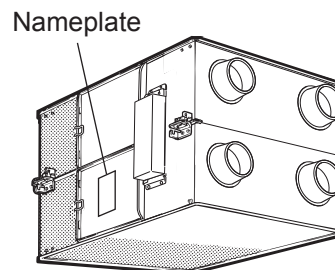
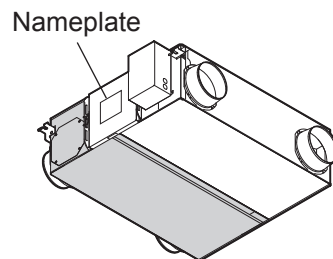

Remote controller (Parts number is not set)

PZ-61DR-E

Filter (Parts number is not set)

PZ-15RF8-E

PZ-25RF8-E

PZ-35RF8-E

PZ-50RF8-E

PZ-65RF8-E

PZ-80RF8-E

PZ-100RF8-E

Warning:









Repair work must be performed by the manufacturer, its service agent or a similarly qualified person in order to avoid hazards.



Contents

1. Safety precautions	3
2. Specifications	4
3. Outside dimensions	5-7
4. Electrical wiring diagrams	8-9
5. Circuit board diagrams	10-11
6. Troubleshooting	12-35
7. Overhauling procedures	36-46
8. Parts catalog	47-105
LGH-15RVX-E	48-53
LGH-25RVX-E	54-59
LGH-35RVX-E	60-65
LGH-50RVX-E	66-71
LGH-65RVX-E	72-77
LGH-80RVX-E	78-83
LGH-100RVX-E	84-89
LGH-150RVX-E	90-97
LGH-200RVX-E	98-105

1. Safety precautions

- Read the following precautions thoroughly before the maintenance, and then inspect and repair the product in a safe manner.
- The types and levels of danger that may arise if the product is handled incorrectly are described with the warning symbols shown below.

 Warning		Incorrect handling of the product may result in serious injury or death.
<p>◇ Electric shock If you must inspect the circuitry while the power is on, do not touch the live parts.</p> <p>(Failure to heed this warning may result in electric shock.)</p> <div style="text-align: right;">  <small>Caution against electric shock</small> </div>	<p>◇ Turn off the power supply Be sure to shut off the power supply isolator before disassembling the unit for repair.</p> <p>(Failure to heed this warning may result in electric shock.)</p> <div style="text-align: right;">  <small>Be sure to follow this instruction.</small> </div>	
<p>◇ Modification is prohibited Do not modify the unit.</p> <p>(Failure to heed this warning may result in electric shock, fire and/or injury.)</p> <div style="text-align: right;">  <small>Prohibited</small> </div>	<p>◇ Use proper parts and tools For repair, be sure to use the parts listed in the service parts list of the applicable model and use the proper tools.</p> <p>(Failure to heed this warning may result in electric shock, fire and/or injury.)</p> <div style="text-align: right;">  <small>Be sure to follow this instruction.</small> </div>	
<p>◇ Proper electric work Use the electric wires designated for electric work, and conduct electric work in accordance with your local "Electric Installation Engineering Standard", the "Indoor Wiring Regulations" and the installation instructions.</p> <p>(Improper connection or wiring installation may result in electric shock and/or fire.)</p> <div style="text-align: right;">  <small>Be sure to follow this instruction.</small> </div>	<p>◇ Replace damaged and/or degraded parts Be sure to replace the power cord and lead wires if they are damaged and/or degraded.</p> <p>(Failure to heed this warning may result in electric shock and/or fire.)</p> <div style="text-align: right;">  <small>Be sure to follow this instruction.</small> </div>	
	<p>◇ Check insulation Upon completing repair work, always measure the insulation resistance. Verify that it is at least 10 MΩ (with a 500-V DC insulation resistance tester), and then turn on the power.</p> <p>(Inadequate insulation may result in electric shock.)</p> <div style="text-align: right;">  <small>Be sure to follow this instruction.</small> </div>	

 Caution		Incorrect handling of the product may result in injury or damage to properties including buildings and equipment.
<p>◇ Caution for injury Do not work at a location where you do not have a sure footing.</p> <p>(Failure to heed this caution may result in a fall.)</p> <div style="text-align: right;">  <small>Prohibited</small> </div>	<p>◇ Wear gloves Wear gloves when servicing.</p> <p>(Failure to heed this caution may result in injury to your hands from sharp metal or other edges.)</p> <div style="text-align: right;">  <small>Be sure to follow this instruction.</small> </div>	

Request for repair

- Inspect the earth condition, and repair it if it is incomplete. Make sure that a power supply isolator or an over-load protection device is installed, if it is not installed, recommend the dealer to install one.
- Make sure that the product operates properly upon completion of repair. Clean the product and the surrounding area, and then notify the customer of the completion of repair.

2. Specifications

Model name	LGH-15RVX-E to LGH-200RVX-E
Heat exchange system	Heat recovery ventilating system
Heat exchanger material	Special treated paper plate heat exchanger
Cladding	Galvanized steel sheet
Heat insulation material	Self-extinguishing urethane foam
Motor	EC motor
Filter	Non-woven fabrics filter (Gravitational method 82% EU-G3)
Surrounding air condition	Shall be between -10°C and 40°C, 80%RH or less
Suction air condition	Shall be lower than 40°C, 80%RH
Supply fan operation under low outdoor temperature	-10°C to -15°C: Intermittent operation 60 min ON, 10 min OFF -15°C or less: Intermittent operation 55 min OFF, 5 min ON
Function	Heat recovery mode/Bypass mode, Fan speed 1, 2, 3, 4
Electrical power supply	220-240 V/50 Hz, 220 V/60 Hz
Insulation resistance	10 MΩ or more
Dielectric strength	1500 V AC 1 minute

Model name	Running current (A)	Input power (W)	Air volume		External static pressure (Pa)	Exchange efficiency (%)			Noise (dB)	Dia. of the centrifugal fan (mm)	Weight (kg)
			(m ³ /h)	(L/S)		Temperature	Enthalpy				
							Heating	Cooling			
LGH-15RVX-E	0.40	49	150	42	95	80	73	71	28	180	20
LGH-25RVX-E	0.48	62	250	69	85	79	69.5	68	27	180	23
LGH-35RVX-E	0.98	140	350	97	160	80	71.5	71	32	220	30
LGH-50RVX-E	1.15	165	500	139	120	78	69	66.5	34	220	33
LGH-65RVX-E	1.65	252	650	181	120	77	68.5	66	34.5	245	38
LGH-80RVX-E	1.82	335	800	222	150	79	71	70	34.5	245	48
LGH-100RVX-E	2.50	420	1000	278	170	80	72.5	71	37	245	54
LGH-150RVX-E	3.71	670	1500	417	175	80	72	70.5	39	245	98
LGH-200RVX-E	4.88	850	2000	556	150	80	72.5	71	40	245	110

*The above values apply during Heat recovery mode ventilation when the fan speed is set to Fan speed 4 at the rating pressure loss and 230 V / 50 Hz.

*For the specifications at the other fan speeds, see the spec. sheets.

*The values given in the table for the noise level reflect the levels measured at a position 1.5 meters immediately below the unit in an anechoic chamber.

*Noise change or increase may occur because of the Bypass-Automatic function or Automatic fan speed change by timer setting and/or other functions.

*Temperature exchange efficiency (%) are based on winter condition.

*Mitsubishi Electric measures products according to Japan Industrial Standard (JIS B 8628), therefore Q-H curves are measured by chamber method.

*On-site commissioning measurements by pitot tube method could be as much 20% different from JIS test room conditions. If the measuring point is close to sources of turbulence like bends, contractions and dampers etc, it is difficult to measure air volume correctly. A straight duct length more than 10D (D=duct diameter) from the source of turbulence is recommended for correct measurement. On-site measurement should therefore be measured in accordance with BSRIA guideline (Commissioning Air System. Application procedures for buildings AG3/89.3(2001))

Model name	PZ-61DR-E
Power supply requirement	12 V DC (Supplied from Lossnay unit)
Power consumption	0.3 W
Transmission cable	Non polarized 2-wire (0.3 mm ² (AWG22) sheathed cable)
Total wiring length	200 m maximum
Number of controllable Lossnay units	15 Lossnay units maximum (Max. 2 remote controllers installable)
Environmental condition	Temperature: 0 to 40°C, Humidity: 30% to 90% relative humidity (no condensation)
Size	120 x 120 x 19 mm
Weight	0.25 kg
Color	Munsell 1.0Y9.2/0.2

3. Outside dimensions

LGH-15RVX-E, LGH-25RVX-E, LGH-35RVX-E, LGH-50RVX-E, LGH-65RVX-E, LGH-80RVX-E, LGH-100RVX-E

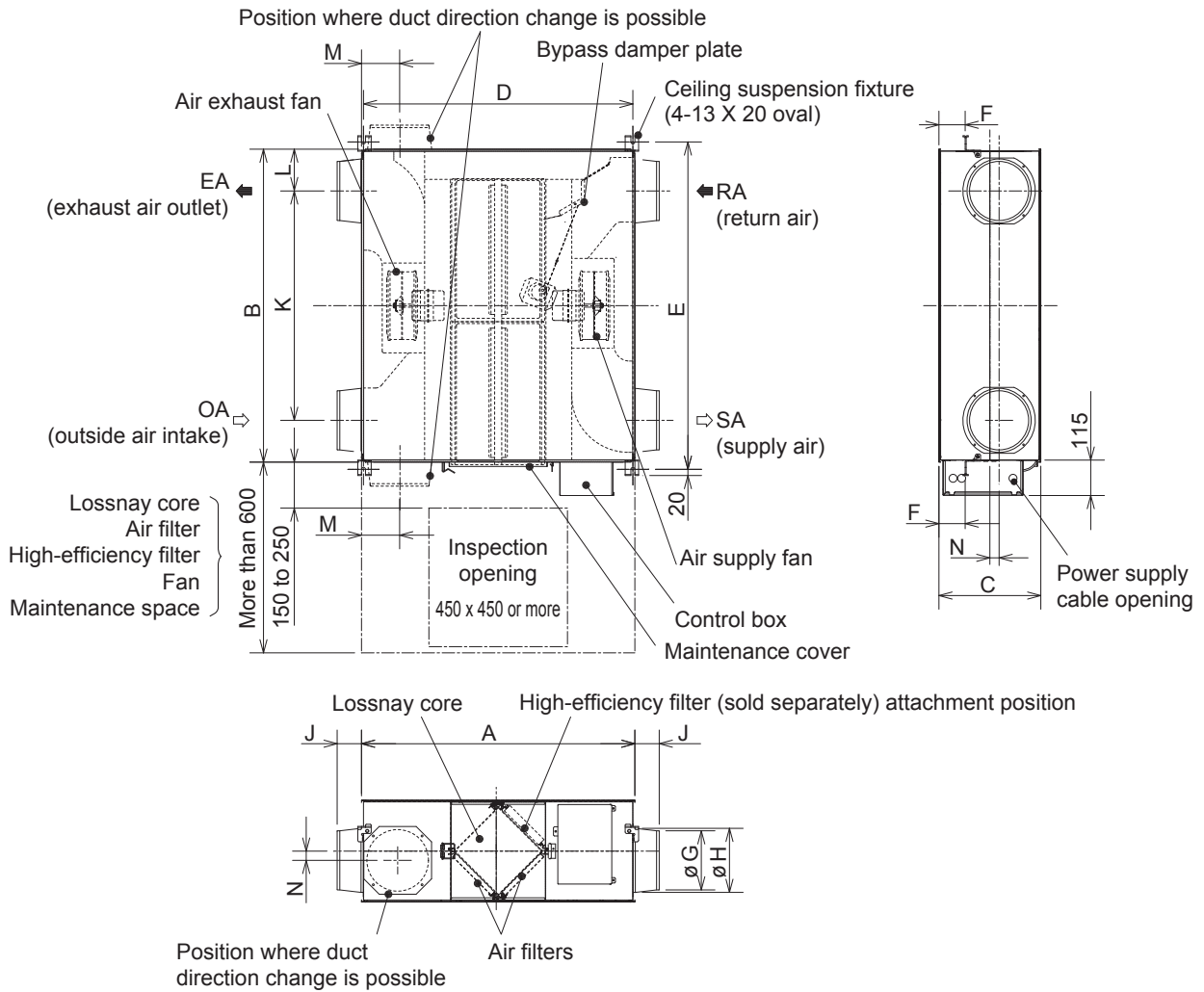

Model	Dimensions			Ceiling suspension fixture pitch			Nominal diameter	Duct connecting flange			Duct pitch				Weight (kg)
	A	B	C	D	E	F		G	H	J	K	L	M	N	
LGH-15RVX-E	780	610	289	768	658	65	100	97.5	110	54	450	80	119	50	20
LGH-25RVX-E	780	735	289	768	782	65	150	142	160	64	530	102.5	102	30	23
LGH-35RVX-E	888	874	331	875	921	85	150	142	160	64	650	112	124	55	30
LGH-50RVX-E	888	1016	331	875	1063	85	200	192	208	79	745	135.5	124	30	33
LGH-65RVX-E	908	954	404	895	1001	70	200	192	208	79	692	131	124	-	38
LGH-80RVX-E	1144	1004	404	1131	1051	77	250	242	258	79	690	157	165	40	48
LGH-100RVX-E	1144	1231	404	1131	1278	77	250	242	258	79	917	157	165	40	54

Unit (mm)

LGH-150RVX-E, LGH-200RVX-E

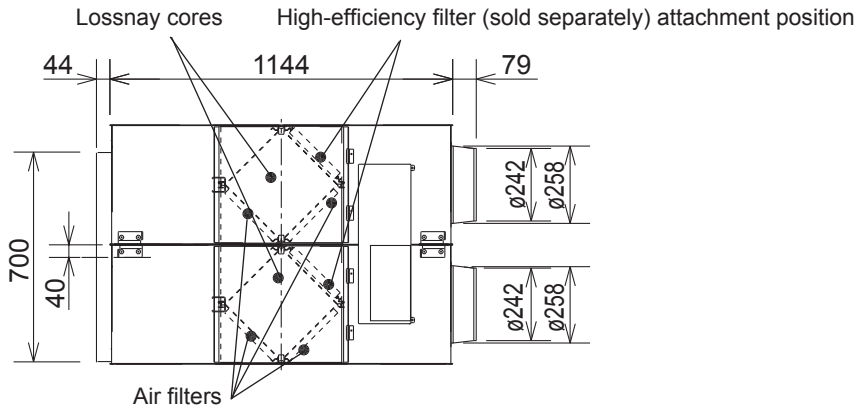
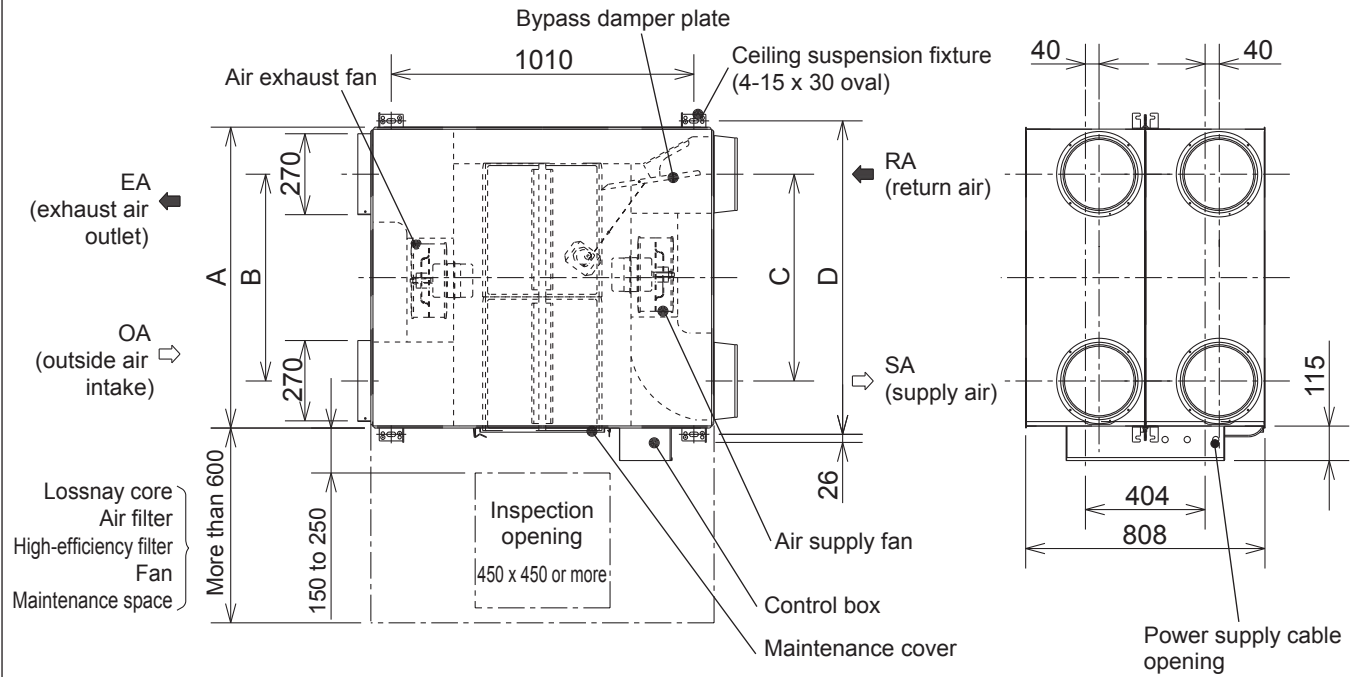

Model	A	B	C	D	Weight (kg)
LGH-150RVX-E	1004	690	690	1045	98
LGH-200RVX-E	1231	917	917	1272	110

Unit (mm)

PZ-61DR-E

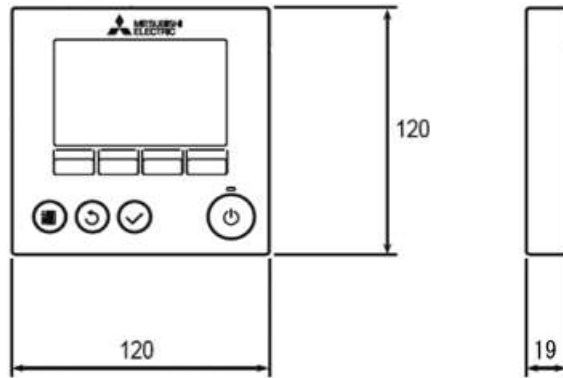

Unit (mm)

PZ-15RF₈-E, PZ-25RF₈-E, PZ-35RF₈-E, PZ-50RF₈-E, PZ-65RF₈-E, PZ-80RF₈-E, PZ-100RF₈-E

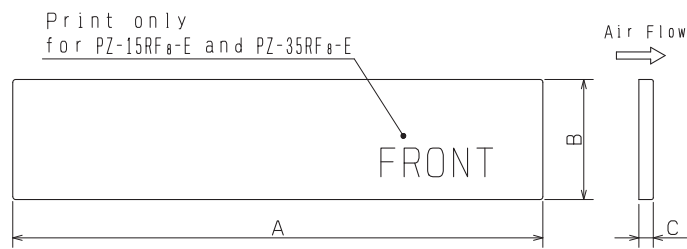

Model	Dimension			The number of filters per set		Applicable model
	A	B	C	Supply	Exhaust	
PZ-15RF ₈ -E	557	130	20	1	1	LGH-15RVX-E
PZ-25RF ₈ -E	333	156	15	2	2	LGH-25RVX-E
PZ-35RF ₈ -E	399	183	20	2	2	LGH-35RVX-E
PZ-50RF ₈ -E	470	183	15	2	2	LGH-50RVX-E
PZ-65RF ₈ -E	433	218	15	2	2	LGH-65RVX-E
PZ-80RF ₈ -E	451	243	15	2	2	LGH-80RVX-E, LGH-150RVX-E (Two sets)
PZ-100RF ₈ -E	565	243	15	2	2	LGH-100RVX-E, LGH-200RVX-E (Two sets)

Notes:

- Each Lossnay unit is provided with one set of the filters. (Two sets for LGH-150RVX-E and LGH-200RVX-E)
- PZ-15RF₈-E and PZ-35RF₈-E has the front and back side. Attach the filter so that the "Front" (printed) side faces the outside.

Unit (mm)

4. Electrical wiring diagrams

LGH-15RVX-E, LGH-25RVX-E, LGH-35RVX-E, LGH-50RVX-E, LGH-65RVX-E, LGH-80RVX-E, LGH-100RVX-E

- * TM1, TM2, TM3, TM4, TB5 shown in dotted lines are field work.
- * Be sure to connect the earth wire.
- * A power supply isolator must be installed.
- * Always use an isolator for the main power connection.

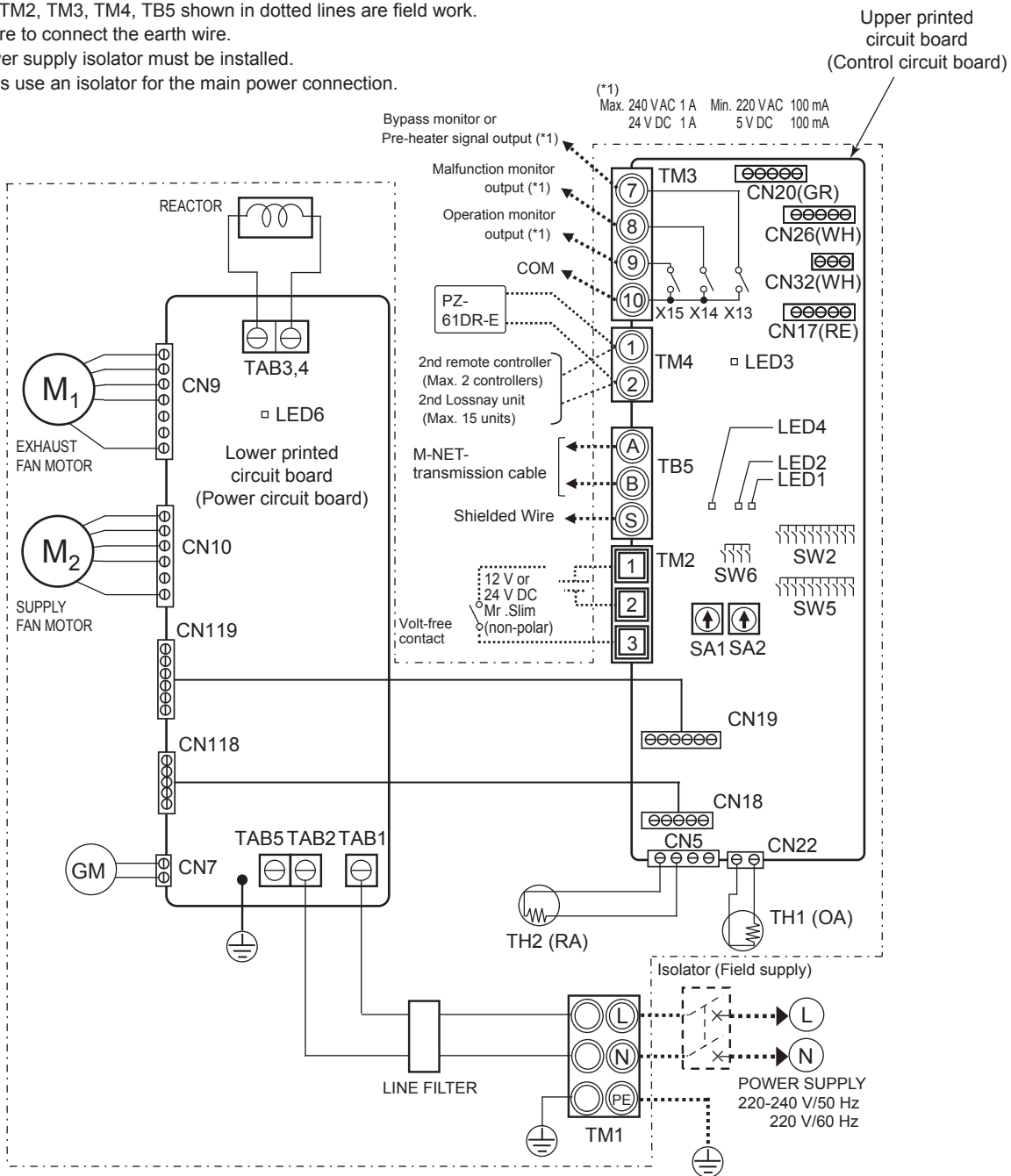

Definition of symbols		
M1: Motor for exhaust fan M2: Motor for supply fan GM: Motor for Bypass damper TH1: Thermistor for outside air TH2: Thermistor for return air SW2, 5: Switch (Function selection) SW6: Switch (Model selection) TM1: Terminal block (Power supply) TM2: Terminal block (External control input) TM3: Terminal block (Monitor output) TM4: Terminal block (Transmission cable) TB5: Terminal block (M-NET Transmission cable)	TAB1, TAB2, (TAB5): Connector (Power supply) TAB3, TAB4: Connector (Reactor) X13: Relay contact X14: Relay contact X15: Relay contact CN5: Connector (Thermistor RA) CN7: Connector (Motor for Bypass damper) CN9: Connector (Fan motor) CN10: Connector (Fan motor) CN17: Connector (Fan speed 1/2/3/4) CN18: Connector CN118: Connector	CN19: Connector CN119: Connector CN20: Unused CN22: Connector (Thermistor OA) CN26: Connector (Bypass, 0 - 10 V DC Fan speed control) CN32: Connector (Remote control selection) SA1: Address setting rotary switch (tens digit) SA2: Address setting rotary switch (ones digit) LED1 to LED3: Inspection indicator lamp LED4, LED6: Power supply indicator lamp SYMBOL : Terminal block : Connector on PCB

Select proper circuit breaker according to the electrical current information in the chart below.

Model	LGH-15RVX-E	LGH-25RVX-E	LGH-35RVX-E	LGH-50RVX-E	LGH-65RVX-E	LGH-80RVX-E	LGH-100RVX-E
Maximum current when operating [A]	0.55	0.72	1.95	2.10	2.50	2.80	3.45
Inrush current after power supply ON [A]	10 ms	6.1					
	100 ms	3.6					

LGH-150RVX-E, LGH-200RVX-E

- * TM1, TM2, TM3, TM4, TB5 shown in dotted lines are field work.
- * Be sure to connect the earth wire.
- * A power supply isolator must be installed.
- * Always use an isolator for the main power connection.

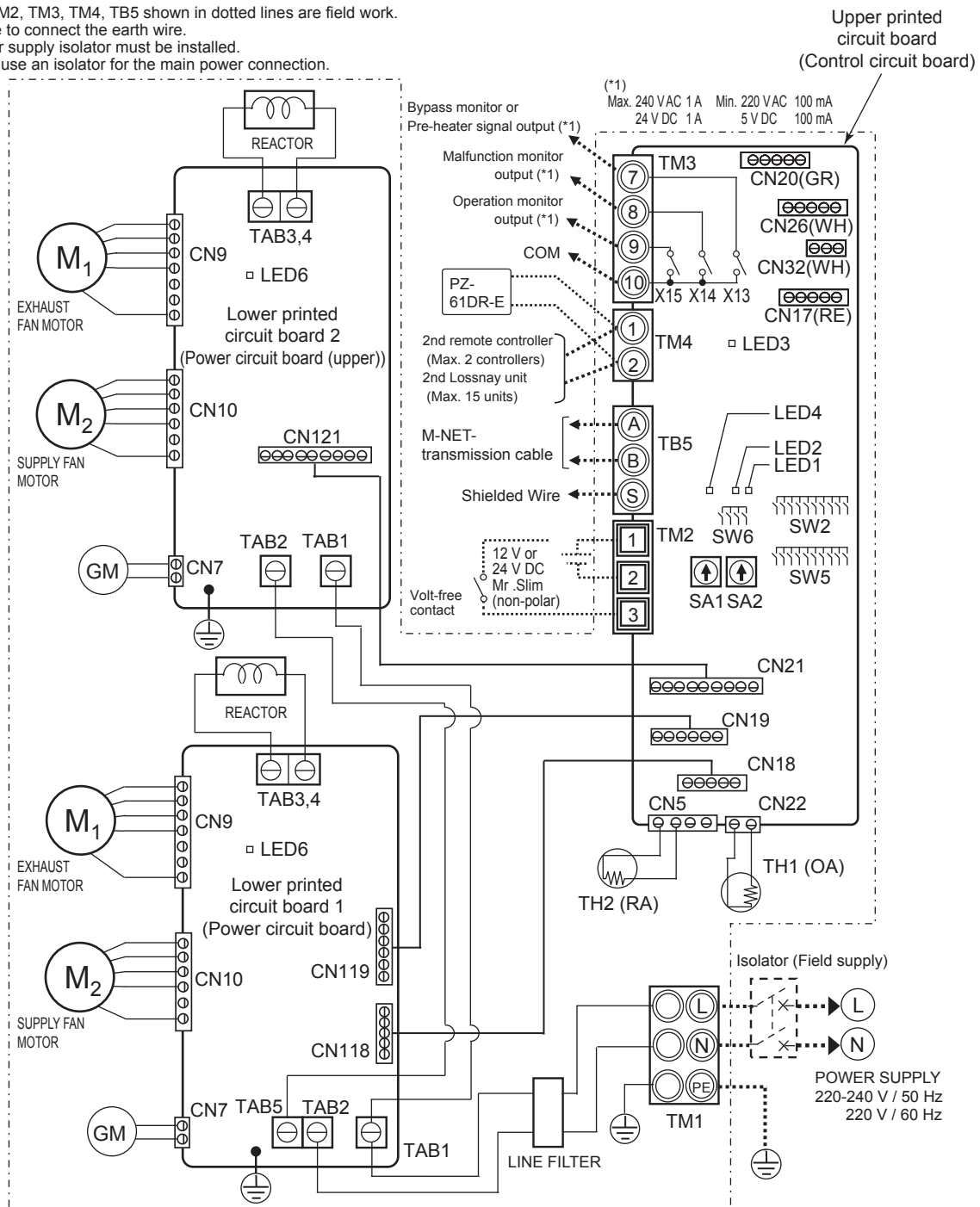

Definition of symbols

M1: Motor for exhaust fan M2: Motor for supply fan GM: Motor for Bypass damper TH1: Thermistor for outside air TH2: Thermistor for return air SW2, 5: Switch (Function selection) SW6: Switch (Model selection) TM1: Terminal block (Power supply) TM2: Terminal block (External control input) TM3: Terminal block (Monitor output) TM4: Terminal block (Transmission cable) TB5: Terminal block (M-NET Transmission cable) TAB1, TAB2, TAB5: Connector (Power supply)	TAB3, TAB4: Connector (Reactor) X13: Relay contact X14: Relay contact X15: Relay contact CN5: Connector (Thermistor RA) CN7: Connector (Motor for Bypass damper) CN9: Connector (Fan motor) CN10: Connector (Fan motor) CN17: Connector (Fan speed 1/2/3/4) CN18: Connector CN118: Connector CN19: Connector CN119: Connector	CN20: Unused CN21: Connector CN121: Connector CN22: Connector (Thermistor OA) CN26: Connector (Bypass, 0 - 10 V DC Fan speed control) CN32: Connector (Remote control selection) SA1: Address setting rotary switch (tens digit) SA2: Address setting rotary switch (ones digit) LED1 to LED3: Inspection indicator lamp LED4, LED6: Power supply indicator lamp SYMBOL \odot \square : Terminal block $\textcircled{\text{X}}$: Connector on PCB
---	---	---

Select proper circuit breaker according to the electrical current information in the chart below.

Model	LGH-150RVX-E	LGH-200RVX-E
Maximum current when operating [A]	5.76	6.34
Inrush current after power supply ON [A]	10 ms	12.2
	100 ms	7.2

(2) Power circuit board

Caution:

The power circuit board is not insulated from the power line (high voltage part), except for the connection part (CN118, CN119, and CN121) with the control circuit board. Also, even when the power supply is cut off, the capacitor is charged. Therefore, wait for at least five minutes before starting work.

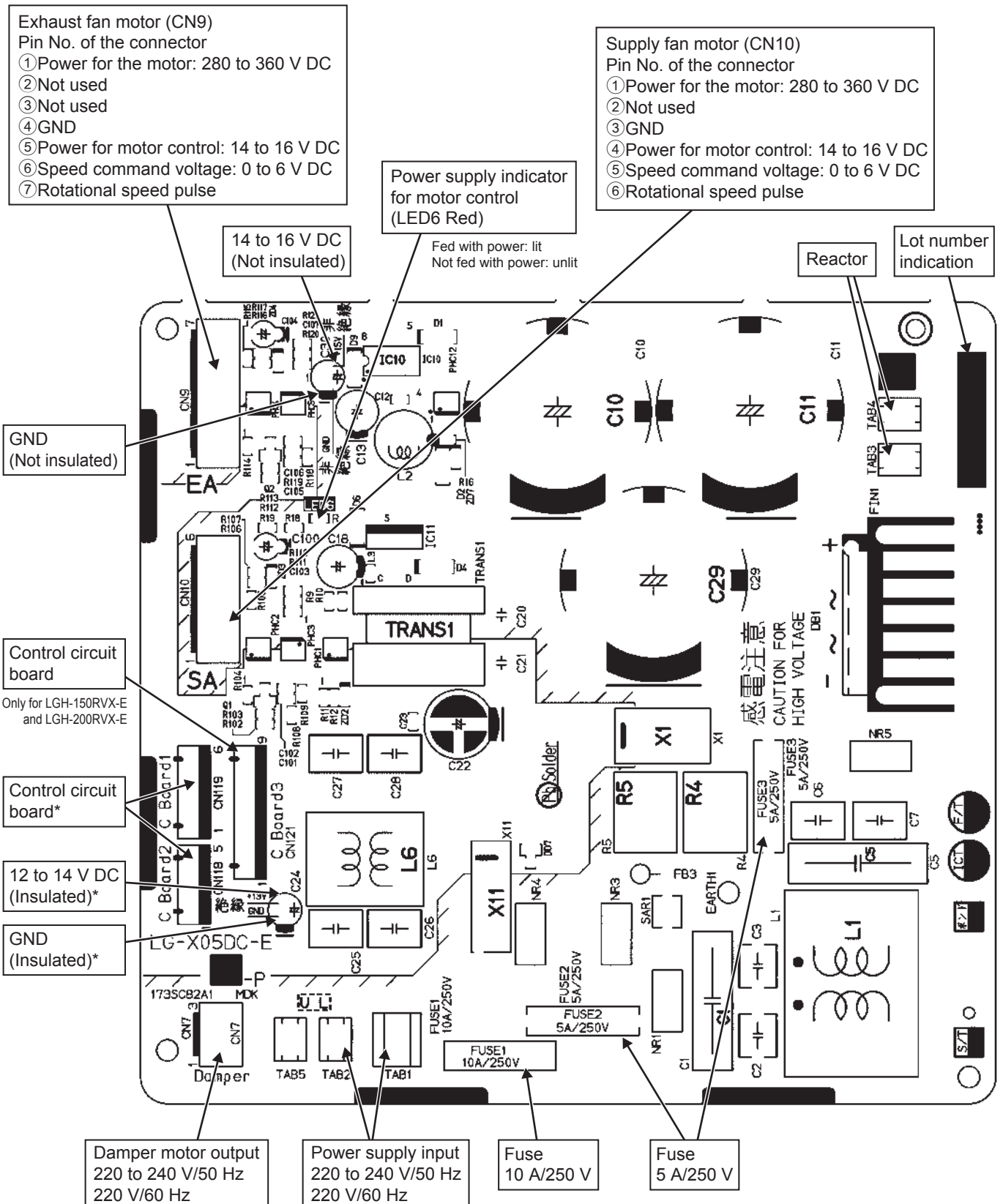

Note:

The components marked with * are not placed on the power circuit board (upper) of LGH-150RVX-E and LGH-200RVX-E.

6. Troubleshooting

■ Work precautions

- When removing or touching the cables, circuit board or other parts, make sure to turn off the power supply isolator.
- Even after the power supply isolator is turned off, the capacitor on the circuit board retains high voltage for a while. Therefore, before servicing, wait for at least five minutes, and then use a tester to check that the voltage has dropped.
- Once the power supply is turned off, be sure to wait for at least five minutes before turning the power back on again.
- When servicing, be sure to recreate the malfunction two or three times before starting repairs.
- When servicing, always take care to keep proper footing.
- Before starting the service, always turn off the power supply isolator. Sufficient care must be taken to avoid electric shock or injury.
- Make sure to connect the power supply wires correctly.
- When removing the circuit board, always hold it at both ends and remove carefully so as not to apply force to the surface mounted parts.
- When removing the circuit board, be careful of the metal edges on the board.
- When removing or inserting the connectors for the circuit board, hold the entire housing section. Never pull on the lead wires.
- If it is thought that there is a circuit board malfunction, check for disconnected wires in the print pattern, burnt parts or discoloration.
- If the circuit board is replaced, make sure that the switch settings on the new board are the same as the old board.

6-1 Service flowchart

After checking the check items below, follow the troubleshooting for servicing.

Applicable Device	Applicable Model
Lossnay Energy Recovery Ventilator	LGH-15RVX-E, LGH-25RVX-E, LGH-35RVX-E LGH-50RVX-E, LGH-65RVX-E, LGH-80RVX-E LGH-100RVX-E, LGH-150RVX-E, LGH-200RVX-E
Lossnay Remote Controller	PZ-61DR-E, PZ-43SMF-E

No.	Preliminary check item	Details
1	Product information	<ul style="list-style-type: none"> • Model name of the product • Serial number of the product, manufacturing lot number of the circuit board • Microcomputer software version marked on the circuit board
2	Fault status	<ul style="list-style-type: none"> • Fault status (For example, the fan does not operate.) • Error code display on the remote controller • Operation setting of the remote controller (ventilation mode setting, fan speed setting, etc.)
3	Frequency of fault occurrence	<ul style="list-style-type: none"> • Frequency of fault occurrence (frequency of date and time of occurrence, regularity of occurrence, etc.) • Operating time up to fault occurrence • Date of start of use, date of fault occurrence
4	Timing of fault occurrence	<ul style="list-style-type: none"> • Remote controller operation performed before fault occurrence • Operating status, etc.
5	System settings	<ul style="list-style-type: none"> • Function selection switch settings and address setting of the product • Model name and address setting of the Lossnay remote controller or system controller, etc. • Function settings on PZ-61DR-E when PZ-61DR-E is used
6	System drawings	<ul style="list-style-type: none"> • System Configuration • Wiring • Record of the Lossnay function setting statuses

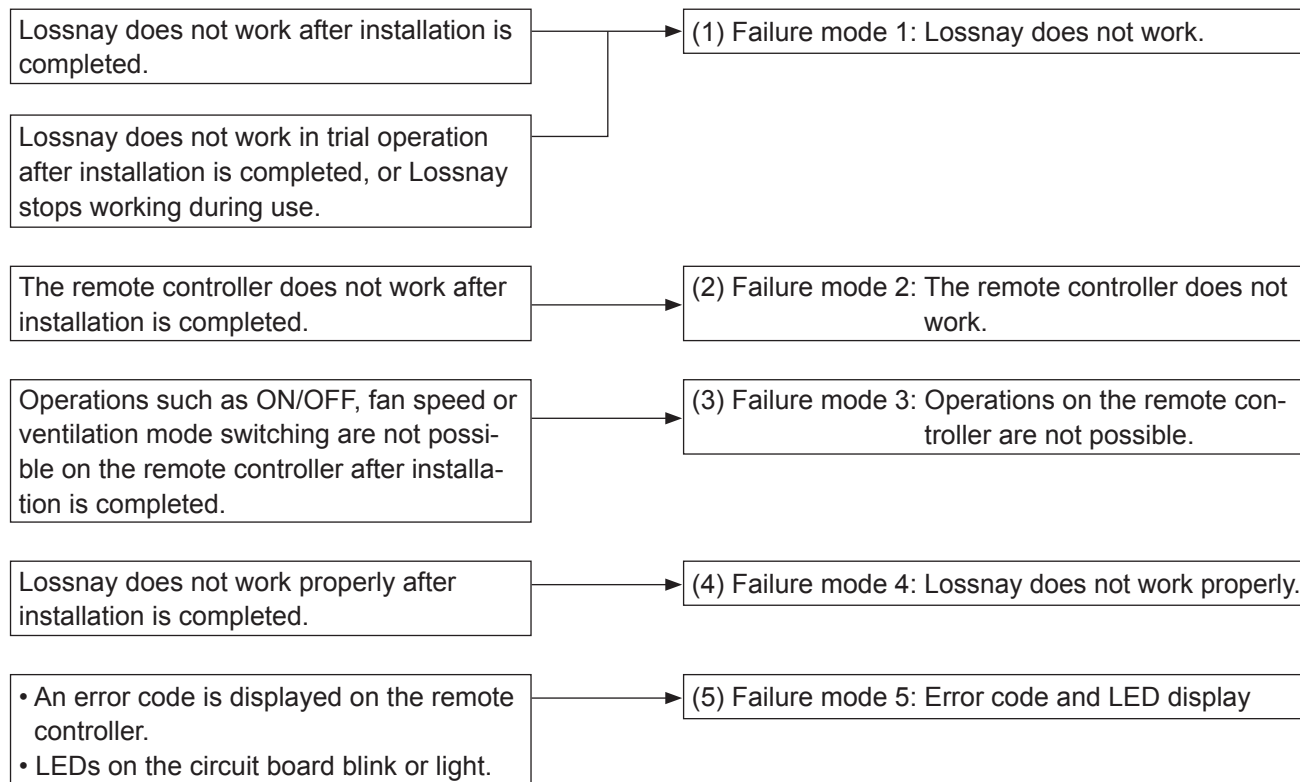

6-2 Check Details

(1) Failure mode 1: Lossnay does not work.

● Initial Check Items

Check the following details if Lossnay does not work after installation is completed.

① Power supply

No.	Check Item	Corrective action
1	Is the main power supply on?	Turn the main power supply on.
2	Is the current capacity of the power supply isolator appropriate?	Use an appropriate power supply isolator.
3	Is the designated cable used for the power supply cable?	Use the designated cable.
4	Is the specified power supply supplied to the power supply terminal (TM1)? 220-240 V/50 Hz, 220 V/60 Hz	Supply the designated power supply.
5	Is the power supply cable incorrectly wired, is there a faulty connection or are screws loose?	Connect the cable securely and correctly, and tighten the screws firmly.
6	Is there a faulty connection on the power supply terminals (TM1, TAB1, TAB2, and TAB5)?	Connect the lead wires securely.
7	Is there a faulty connection on the reactor terminals (TAB3 and TAB4)? For LGH-150RVX-E and LGH-200RVX-E, check both the power circuit board and power circuit board (upper).	Connect the lead wires securely.
8	Are the power supply indicator lamps (LED4 and LED6, red) lit? For LGH-150RVX-E and LGH-200RVX-E, check both the power circuit board and power circuit board (upper).	Check the above items.

② Transmission cables (remote controller transmission cable, M-NET transmission cable, and external input/output signal cable)

No.	Check Item	Corrective action
1	Are the designated cables used for the remote controller transmission cable and M-NET transmission cable? (See Table 2-1 and Table 2-2.)	Use the designated transmission cables.
2	Are the designated cables used for the external input/output signal cable? (See Table 2-3.)	Use the designated cables.
3	Are the transmission cables wired using multicore cables?	Use the designated transmission cables.
4	Are multiple transmission cables wired in the same piping duct?	Wire the transmission cable away from one another.
5	Is the power supply cable wired at least 5 cm away from transmission cables?	Wire the power supply cable at least 5 cm away from the transmission cables.
6	Are the transmission cables connected to the designated terminal block? (See Table 2-1 and Table 2-2.)	Connect the transmission cables to the designated terminal blocks.
7	Are the transmission cables incorrectly wired, is there a faulty connection or are screws loose?	Connect the cable securely and correctly, and tighten the screws firmly.
8	Is the wiring length of the transmission cable within the regulations? (See Table 2-1 and Table 2-2.)	Wire the cables within the regulations.
9	Does the external input signal match the specifications? (See Table 2-3.)	Input the signal that matches the specifications.
10	Is the external input signal input to the Lossnay set as the main Lossnay?	Input the signal to the Lossnay set as the main Lossnay (SW5-10 ON).
11	Is the function selection for the external output signal set correctly?	Set the function selection switches (SW2-8, 5-2, and 5-6) on the circuit board correctly. Set the function settings (No. 57 and 58) of PZ-61DR-E correctly.

Table 2-1
M-NET transmission cable specifications

Cable	M-NET transmission cable
Type	Shielded cable CVVS, CPEVS
Number of cores	2-core cable
Cable diameter	1.25 mm ² to 2.0 mm ²
Max. extension	200 m (Note 1)
Total extension	500 m (Note 2)
Terminal block	TB5 [A] [B]

Table 2-2
Remote controller transmission cable specifications

Cable	PZ-61DR-E or PZ-43SMF-E transmission cable
Type	Sheathed cable
Number of cores	2-core cable
Cable diameter	0.3 mm ² (AWG22)
Total extension	200 m
Terminal block	TM4 ① ②

(Note 1) Distance from the power supply unit to the furthest unit or system controller

(Note 2) Overall length of the cable between the units and the system controllers

Table 2-3 External input/output specifications

Function Name	Terminal or connector on the circuit board	Signal specifications	Materials Used	Total extension
External control input (volt-free contact)	TM2 ①③	Level/pulse (Note 1)	Single-lead 0.8 to 1.2 mm dia. or twisted lead 0.5 to 1.5 mm ²	500 m
External control input (12 V DC, 24 V DC)	TM2 ①②	Level/pulse (Note 1)	Single-lead 0.8 to 1.2 mm dia. or twisted lead 0.5 to 1.5 mm ²	(Note 2)
Mr. Slim indoor unit control signal	TM2 ①②	Serial signal	Slim-Lossnay connection cable (Accessory parts)	500 m
Remote/local switching	CN32 ①③	Level (Note 1)	Remote ON/OFF adaptor (PAC-SE55RA-E)	10 m
Remote ON/OFF input	CN32 ①②			
Fan speed 4 input (volt-free contact)	CN17 ①②	Level (Note 1)	Remote display adaptor (PAC-SA88HA-E)	
Fan speed 3 input (volt-free contact)	CN17 ①③			
Fan speed 2 input (volt-free contact)	CN17 ①④			
Fan speed 1 input (volt-free contact)	CN17 ①⑤			
Bypass mode input (volt-free contact)	CN26 ①②			
Fan speed switching input (0 to 10 V DC)	CN26 ④⑤	Analog		

<Caution>

- Input the signals to the Lossnay (SW5-10 ON, with the smallest address setting) set as the main Lossnay in the group.

(Note 1) The input signal must conform to the following specifications:

Level signal Volt-free contact, 12 V DC, 24 V DC, the duration of ON and OFF should be 10-second or more.

Pulse signal Volt-free contact, 12 V DC, 24 V DC, the duration of ON should be 200 msec. or more, and minimum 10-second absence is necessary to the next pulse .

In the case of relay contact input, use a relay having a contact rating of 15 V DC/0.1 A or higher and a minimum applicable load of 1 mA or less.

(Note 2) Check the specifications of the external device.

③ Monitor output signal cable

No.	Check Item	Corrective action
1	Is the signal cable wired by multicore cable?	Wire the cable using a 2-core cable.
2	Are the signal cables and transmission cables wired in the same piping duct?	Wire the signal cables away from the transmission cables.
3	Is the power supply cable wired at least 5 cm away from signal cables?	Wire the power supply cable at least 5 cm away from the signal cables.
4	Is the signal cable connected to the designated terminal block? (See Table 3-1.)	Connect the signal cable to the designated terminal block.
5	Is the signal cable incorrectly wired, is there a faulty connection or are screws loose?	Connect the cable securely and correctly, and tighten the screws firmly.
6	Is the output capacity of the signal cable within rating? (See Table 3-1.)	Use the signal cable within rating.
7	Is the function selection for the external output signal set correctly?	Set the function selection switches (SW2-8, 5-2, and 5-6) on the circuit board correctly. Set the function settings (No. 57 and 58) of PZ-61DR-E correctly. (See the Lossnay technical manual.)

Table 3-1 Monitor Output Specifications

Terminal block	TM3 ⑨⑩	TM3 ⑧⑩	TM3 ⑦⑩
Function Name	Operation monitor	Malfunction monitor	Bypass monitor or Pre-heater
Signal specifications	Volt-free contact		
Output rating	240 V AC, 1 A		
	24 V DC, 1 A		
Min. applicable load	220 V AC, 100 mA		
	5 V DC, 100 mA		

④ Function setting (See the Lossnay technical manual for details.)

No.	Check Item	Corrective action
1	Is the main Lossnay set correctly?	Check the function selection switch (SW5-10) on the circuit board. When an external signal is input to multiple Lossnay units, set one of the units in the group as the main Lossnay (SW5-10 ON).
2	Are the function selection switches on the circuit board set correctly to suit the required application?	Set the function selection switches (SW2 and SW5) on the circuit board correctly.
3	Is the applicable model used as the Lossnay remote controller?	Use PZ-61DR-E or PZ-43SMF-E. (The air conditioner remote controller including PAR-31MAA cannot be used.)
4	When PZ-61DR-E is used, are the function selections set correctly to suit the required application?	Set the function selections correctly.
5	Was a function set with the function selection switches on the circuit board after the function is set with PZ-61DR-E?	Set the function again with PZ-61DR-E. For the function that can be set with both PZ-61DR-E and the function selection switches, if the function is set to other than "DIP-SW priority" with PZ-61DR-E, setting with the function selection switches is disabled.
6	Is the Lossnay address set correctly?	Set the address setting switches (SA1 and SA2) correctly.

⑤ LED Indications on the circuit board

No.	LED	Contents	Check Item	Corrective action
1	LED1 (green)	Lossnay main unit error indicator	Blinking: Starting up, error occurred	See Failure Mode 5.
			Lit: During delay operation	Lossnay operates after the delay time has passed.
			Unlit: Other than above	It is normal.
2	LED2 (red)	M-NET System error indicator	Blinking: Error occurred	See Failure Mode 5.
			Lit: No M-NET connection informa- tion	When using M-NET, perform group reg- istration with the system controller.
			Unlit: Other than above	It is normal.
3	LED3 (green)	Remote control- ler power supply indicator	Lit: Power supplied to the remote controller (Main Lossnay)	The LED goes out when power is sup- plied to the remote controller from other Lossnay units in a multiple Lossnay group.
			Unlit: Power not supplied to the remote controller (Sub Lossnay)	
4	LED4 (red)	Power supply indicator (control circuit board)	Check that this LED is lit	The LED lights while power is being supplied to the control circuit board.
5	LED6 (red)	Power supply indicator (power circuit board)	Check that this LED is lit	The LED lights while power is being supplied to the power circuit board. (Do not touch components on the circuit board when the LED is lit.)

● **Individual function check items**

If Lossnay does not work in the trial operation after installation is completed, or if Lossnay stops working during use, check the following items.

No.	Problem	Factor	Corrective action
1	The fan does not operate even through the trial operation switch (SW2-1) on the circuit board is turned ON.	The connectors between the fan motor and circuit board is disconnected.	Check the connector (CN9) for the exhaust fan motor and the connector (CN10) for the supply fan motor.
		The connector between the control circuit board and power circuit board is disconnected.	Check the connector connections (CN18-CN118 and CN19-CN119). Check the connector connection (CN21-CN121). (For LGH-150RVX-E and LGH-200RVX-E only)
		The model selection switch (SW6) is not set correctly.	Make the SW6 setting appropriate for the model. (See chapter 7. (8) Setting status record (page 46).)
		The temperature around the product is high.	Use the product at a temperature of 40°C or lower.
		Fan motor failure	Check the resistance between the motor leads. (See chapter 6. (7) Motor resistance table (page 35).) If the measured value is significantly different from the values specified in the table, replace the fan motor.
		Circuit board failure	Disconnect the connectors (CN9 and CN10), and check the output voltage of each pin of the connectors within one minute after turning the switch (SW2-1) ON. (One minute later, the error will occur.) (See chapter 5. (2) Power circuit board (page 11).) If the voltage value is abnormal, replace the circuit board. If the problem persists, replace the fan motor.
2	Though the remote controller display indicates the fan is running, the fan stops by itself.	The Lossnay unit is operating in the protective mode (intermittent operation).	When PZ-61DR-E is used, it displays the icon "⚠" that indicates the protective operation is in-progress. For details, see the Lossnay technical manual or remote controller manual.
		The Lossnay unit is set to the delay operation.	When PZ-61DR-E is used, it displays the icon "⌚" that indicates the delay operation is in-progress. LED1 (green) on the control circuit board lights. Lossnay operates in 30 minutes (or 15 minutes) after the air conditioner is operated to run. Check the function selection switch (SW5-1) on the circuit board or the function setting (No. 9) of PZ-61DR-E. (See the Lossnay technical manual.)
		The interlocked air conditioner (Mr. Slim indoor unit or City Multi indoor unit) is defrosting.	The supply fan has been stopped to prevent cold air from blowing out. When the air conditioner finishes defrosting, the fan operation is started automatically.
		The system is switching the ventilation mode.	When switching the ventilation mode (Energy recovery mode/Bypass mode), the fan stops (for approx. 30 seconds).
		The temperature around the product is high.	When the ambient temperature of the product is high (higher than 40°C), the fan may stop to prevent the fan motor from overheating.

No.	Problem	Factor	Corrective action
3	The fan does not stop even though the remote controller is operated to stop operation.	The pre-heater or operation monitor with delay operation is set to be used.	If the pre-heater or operation monitor with delay operation is set to be used, the fan continues operating for three minutes after the stop operation. Check the function selection switches (SW2-8 and 5-6) on the circuit board or the function settings (No. 57 and 58) of PZ-61DR-E. (See the Lossnay technical manual.)
4	Even though the remote controller is operated to change the fan speed, the fan speed does not change.	The indoor negative pressure setting or the indoor positive pressure setting is set.	Check the function selection switches (SW2-4 and 2-5) on the circuit board or the function settings (No. 6 and 7) of PZ-61DR-E. (See the Lossnay technical manual.)
		The external fan speed input is set. (CN17)	When PZ-61DR-E is used, it displays the icon "🌀". Check the fan speed switching input (CN17).
		The external fan speed input is set. (CN26)	When PZ-61DR-E is used, it displays the icon "🌀". Check the function selection switches (SW2-3 and 2-6) on the circuit board or the function setting (No. 63) of PZ-61DR-E. (See the Lossnay technical manual.)
		The system is operating in the protective mode (intermittent operation).	When PZ-61DR-E is used, it displays the icon "🛑" that indicates the protective operation is in-progress. For details, see the Lossnay technical manual or remote controller manual.
		The pre-heater is ON.	When the pre-heater is ON, Lossnay runs at Fan speed 2 or higher speed. Even when Fan speed 1 is selected with the remote controller or external fan speed input, Lossnay runs at Fan speed 2.
5	The fan operation is unstable.	The motor rotation speed is under control.	This product controls the motor by detecting the motor rotation speed. The fan operation may be unstable during rotation speed control (for maximum about 10 minutes).
6	Air volume is abnormally large or small.	The model selection switch (SW6) is not set correctly after the circuit board is replaced.	Make the SW6 setting appropriate for the model. (See chapter 7. (8) Setting status record (page 46).)
7	The damper does not operate even through the trial operation switch (SW2-1) on the circuit board is turned ON.	The connector between the damper motor and circuit board is disconnected.	Check the connection of the connector (CN7) on the power circuit board.
		Mechanical failure	Remove the rod of the damper board and check if the damper board can be moved by hand.
		Damper motor failure	Remove the rod of the damper board and turn the trial operation switch (SW2-1) ON. The damper motor operates in about 30 seconds. If the damper motor does not operate, replace the damper motor (GM assembly).
		Circuit board failure	Disconnect the connector (CN7) from the power circuit board and check the voltage value between the pins of CN7 when the trial operation switch (SW2-1) is turned ON. (Voltage is output in about 30 seconds after switch ON.) If there is no voltage value, replace the circuit board. If the problem persists, replace the damper motor (GM assembly).

No.	Problem	Factor	Corrective action
8	Even though the remote controller is operated to change the ventilation mode, the ventilation mode is not changed.	The outdoor temperature is 8°C or lower.	When the outdoor temperature is 8°C or lower, the ventilation mode is fixed to the Energy recovery mode.
		The signal is input to the Bypass mode switching input (CN26 ① ②).	Check the Bypass mode switching input (CN26 ① ②). (See the Lossnay technical manual.)
		The pre-heater is ON, or within one hour after the pre-heater is turned OFF.	When the pre-heater is ON, or for one hour after the pre-heater is turned OFF, the ventilation mode is fixed to the Energy recovery mode.
9	The ventilation mode cannot be switched when Lossnay is operating in the automatic mode.	Temperature condition for Energy recovery mode or Bypass mode is not satisfied.	Check the temperature map. For details, see the Lossnay technical manual.
		It has not passed 30 minutes since the ventilation mode is switched.	Switching of the ventilation mode is controlled in 30 minutes cycle.
		The outdoor temperature is 8°C or lower.	When the outdoor temperature is 8°C or lower, the ventilation mode is fixed to the Energy recovery mode.
		The signal is input to the Bypass mode switching input (CN26 ① ②).	Check the Bypass mode switching input (CN26 ① ②). (See the Lossnay technical manual.)
		The operation mode of the interlocked air conditioner (Mr. Slim indoor unit or City Multi indoor unit) is set to fan operation or heating.	If the operation mode of the interlocked air conditioner is fan operation or heating, the ventilation mode of Lossnay is fixed to the Energy recovery mode.
		The pre-heater is ON, or within one hour after the pre-heater is turned OFF.	When the pre-heater is ON, or for one hour after the pre-heater is turned OFF, the ventilation mode is fixed to the Energy recovery mode.
10	Air volume is too small.	Is the air filter clogged?	Clean the air filter.
		Pressure loss in the duct is too high.	Set the supply/exhaust fan power up setting. (See the Lossnay technical manual.)
		The model selection switch (SW6) is not set correctly after the circuit board is replaced.	Make the SW6 setting appropriate for the model. (See chapter 7. (8) Setting status record (page 46).)
		The indoor negative pressure setting or the indoor positive pressure setting is set.	Check the function selection switches (SW2-4 and 2-5) on the circuit board or the function settings (No. 6 and 7) of PZ-61DR-E. (See the Lossnay technical manual.)
		Power supply voltage is low.	Check the power supply voltage.
		In interlock with the air conditioner, the outdoor air intake port of the Lossnay unit is connected with the air conditioner by using a duct.	In this case, even if the Lossnay remote controller is operated to start Lossnay while the air conditioner is stopped, Lossnay will not supply air.

(2) Failure mode 2: The remote controller does not work.

If the remote controller does not work after installation is completed, check the following items.

①PZ-61DR-E

No.	Problem	Factor	Corrective action
1	Nothing is displayed on the remote controller. The ON/OFF lamp does not blink.	The power of the Lossnay unit is not ON.	Check the items described in (1) ①.
		Faulty connection of the remote controller transmission cable	Check the items described in (1) ②.
		In one group, three or more PZ-61DR-E controllers are connected.	Only up to two PZ-61DR-E controllers can be connected in one group.
		In one group, 16 or more Lossnay units are connected.	Only up to 15 Lossnay units can be connected in one group.
		The wiring length of the remote controller exceeds 200 m.	The wiring length of the remote controller shall be within 200 m.
		In one group, two or more Lossnay units are set as the main Lossnay (SW5-10 ON).	Only one Lossnay unit can be set as the main Lossnay in one group.
2	The remote controller continues to display "Please Wait". Error code "6831" is displayed.	The remote controller is starting up.	The remote controller displays "Please Wait" during start-up for maximum four minutes.
		Faulty connection of the remote controller transmission cable	Check the items described in (1) ②.
		The remote controller transmission cable is connected to the terminal block (TB5 [A] [B]) for the M-NET transmission cable.	Connect the remote controller transmission cable to the terminal block (TM4 ① ②).
		PZ-43SMF-E is used together.	PZ-61DR-E and PZ-43SMF-E cannot be used together.
3	It takes time for the remote controller to be fed with power after turning the Lossnay unit ON.	The Lossnay unit is starting up.	The remote controller is not fed with power during start-up of the Lossnay unit for maximum one minute.

②PZ-43SMF-E

No.	Problem	Factor	Corrective action
1	The power indicator "●" is not displayed.	The power of the Lossnay unit is not ON.	Check the items described in (1) ①.
		Faulty connection of the remote controller transmission cable	Check the items described in (1) ②.
		In one group, three or more PZ-43SMF-E controllers are connected.	Only up to two PZ-43SMF-E controllers can be connected in one group.
		In one group, 16 or more Lossnay units are connected.	Only up to 15 Lossnay units can be connected in one group.
		The wiring length of the remote controller exceeds 200 m.	The wiring length of the remote controller shall be within 200 m.
		In one group, two or more Lossnay units are set as the main Lossnay (SW5-10 ON).	Only one Lossnay unit can be set as the main Lossnay in one group. (See the Lossnay technical manual.)
2	"H0" is displayed on the remote controller.	The remote controller is starting up.	The remote controller displays "H0" during start-up for a maximum of one minute.

No.	Problem	Factor	Corrective action
3	It takes time for the remote controller to be fed with power after turning the Lossnay unit ON.	The Lossnay unit is starting up.	The remote controller is not fed with power during start-up of the Lossnay unit for a maximum of one minute.
4	The inspection number "6801" is displayed on the remote controller.	Faulty connection of the remote controller transmission cable	Check the items described in (1) ②.
		The remote controller transmission cable is connected to the terminal block (TB5 [A] [B]) for the M-NET transmission cable.	Connect the remote controller transmission cable to the terminal block (TM4 ① ②).
		PZ-61DR-E is used together.	PZ-43SMF-E and PZ-61DR-E cannot be used together.

(3) Failure mode 3: Operations on the remote controller are not possible.

● Initial Check Items

If the system cannot be operated with the remote controller after installation is completed, check the following items.

No.	Check item	Notes
1	Are the function selection switches (SW2 and SW5) on the Lossnay circuit board set correctly to suit the required application?	Depending on the settings of the function selection switches, Lossnay may automatically operate or stop, or specific operation may be unable to be performed with the remote controller.
2	When PZ-61DR-E is used, are the function selections set correctly to suit the required application?	Depending on the settings of the function selections, Lossnay may automatically operate or stop, or specific operation may be unable to be performed with the remote controller.
3	When PZ-61DR-E is used, are icons and characters displayed on the PZ-61DR-E screen?	Based on the icon and characters, you can check statuses such as the timer operation, Night-purge, and protective operation. (See the Lossnay technical manual.)
4	Is the system controller of M-NET used?	The system controller can be used to start/stop Lossnay, change fan speed or ventilation mode, and prohibit the start/stop operation by PZ-61DR-E.
5	Is the external input used?	If the interlock mode is set to the "External input priority ON/OFF interlock" and if the external device is operating, the stop operation by PZ-61DR-E is prohibited. (See the Lossnay technical manual.)
		If the Remote/Local switching (CN32) is set to remote, the start/stop operation by the Lossnay remote controller is prohibited. (See the Lossnay technical manual.)
		Priority is given to the operation by the fan speed switching input and Bypass mode switching input. (CN17, CN26) (See the Lossnay technical manual.)

● Individual check items

If the system cannot be started/stopped using the remote controller after installation is completed, check the following items.

① PZ-61DR-E

No.	Problem	Factor	Corrective action
1	Some Lossnay units in the group do not operate.	The power of the Lossnay unit is not ON.	Check the items described in (1) ①.
		Faulty connection of the remote controller transmission cable	Check the items described in (1) ②.
		The remote controller transmission cables are not correctly connected between the terminals (TM4 ①②) of the Lossnay units in the group.	Connect the remote controller transmission cables correctly between the terminals (TM4 ①②) of the Lossnay units in the group.
		The system is operating in the protective mode (intermittent operation).	For details, see the Lossnay technical manual.
2	The screen display of the remote controller changes by itself. Even if you press the buttons, the screen returns to the original screen right away.	Faulty connection of the remote controller transmission cable	Check the items described in (1) ②.
		The group wiring and the group setting of the system controller do not match.	Check the group wiring or the group setting of the system controller.
		When the system controller is used, the Lossnay unit, which is set as the main Lossnay (SW5-10 ON), is not set to the address with the smallest number in the group.	Set the Lossnay unit, which is set as the main Lossnay (SW5-10 ON) to the address with the smallest number. (See the Lossnay technical manual.)
3	The ventilation mode cannot be changed with the remote controller.	The Lossnay unit is performing the Night-purge operation.	The ventilation mode cannot be changed during the Night-purge operation. (See the Lossnay technical manual.)
		The signal is input to the Bypass mode switching input (CN26 ①②).	Check the Bypass mode switching input (CN26 ①②). (See the Lossnay technical manual.)
4	Even though the function settings (No. 37 and/or 38) of PZ-61DR-E are set to "1", the indoor temperature and/or supply air temperature are not displayed.	The Lossnay unit is performing the Bypass mode ventilation.	The indoor temperature and/or supply air temperature are not displayed during the Bypass mode.
5	Even though the function settings (No. 36, 37 and/or 38) of PZ-61DR-E are set to "1", the outdoor temperature, indoor temperature and/or supply air temperature are not displayed.	The setting of PZ-61DR-E is not correct.	Select "Yes" at "Temp. display" menu of PZ-61DR-E. For details, see the installation manual of PZ-61DR-E.
6	The indoor, outdoor, and/or supply air temperature display of PZ-61DR-E blink.	The indoor, outdoor, and/or supply air temperature are outside the measurement range.	In the following cases, the temperature display blinks. Outdoor temperature: 0°C or lower, 38°C or higher Indoor and supply air temperature: 8°C or lower, 38°C or higher

② Interlocking with air conditioners (Mr. Slim indoor unit or City Multi indoor unit) or external devices

No.	Problem	Factor	Corrective action
1	Lossnay interlock settings cannot be performed with the remote controller.	The power of the Lossnay unit is not ON.	Check the items described in (1) ①.
		Faulty connection of the remote controller transmission cable	Check the items described in (1) ②.
		Lossnay address setting is incorrect.	Check the Lossnay address.
2	Lossnay does not perform interlock operation.	The power of the Lossnay unit is not ON.	Check the items described in (1) ①.
		Faulty connection of the remote controller transmission cable or external input/output signal cables	Check the items described in (1) ②.
		The Lossnay unit is not set for interlock operation.	Set the interlock setting.
		The terminal block connected and the type of external signal do not match (charged or volt-free)	Check the type of external signal and the connections of the external control input terminal (TM2).
		The type of external signal and input setting do not match (level signal or pulse signal).	Check the type of external signal and the setting of the input (level or pulse). (See the Lossnay technical manual.)
		The Lossnay unit is set to the delay operation.	When PZ-61DR-E is used, it displays the icon "Ⓜ" that indicates the delay operation is in-progress. LED1 (green) on the control circuit board lights. The Lossnay unit starts operation in 30 minutes (or 15 minutes) after starting operation by the air conditioner or external signal. Check the function selection switch (SW5-1) on the circuit board or the function setting (No. 9) of PZ-61DR-E. (See the Lossnay technical manual.)
		The interlock mode of the Lossnay unit is set to "ON Interlock" or "OFF Interlock".	Check the interlock mode setting. (See the Lossnay technical manual.)
		In a group of multiple Lossnay units, no Lossnay unit is set to the main Lossnay.	For a group of multiple Lossnay units, set one Lossnay unit as the main Lossnay (SW5-10 ON) to input external control signal. (See the Lossnay technical manual.)
		In a group of multiple Lossnay units, external control signal is input to a Lossnay unit other than the main Lossnay.	
The Lossnay unit is operating in the protective mode (intermittent operation).	For details, see the Lossnay technical manual.		

③System controller

No.	Problem	Factor	Corrective action
1	The group of Lossnay cannot be set with the system controller.	The power of the Lossnay unit is not ON.	Check the items described in (1) ①.
		M-NET transmission cable is connected to the remote controller terminal block (TM4 ①②).	Connect the M-NET transmission cable to the M-NET transmission cable terminal block (TB5 [A] [B]).
		Lossnay address setting is incorrect.	Check the address setting switches (SA1 and SA2) on the Lossnay circuit board.
		Power is not supplied to the M-NET transmission cable.	If the system is configured with only Lossnay units, connect the power supply unit. (See the Lossnay technical manual.)
		The wiring length of the M-NET transmission cable is longer than specified. (Longer than 200 m from the power supply unit, or longer than 500 m in total length)	Check the wiring length of the transmission cable. (See the Lossnay technical manual.)
2	Some Lossnay units in the group do not operate.	The power of the Lossnay unit is not ON.	Check the items described in (1) ①.
		Faulty connection of the M-NET transmission cable	Check the items described in (1) ②.
		The remote controller transmission cables are not correctly connected between the terminals (TM4 ①②) of the Lossnay units in the group.	Connect the remote controller transmission cables correctly between the terminals (TM4 ①②) of the Lossnay units in the group.
		The Lossnay unit is operating in the protective mode (intermittent operation).	For details, see the Lossnay technical manual.
3	The screen display of the system controller changes by itself. Even if you press the buttons, the screen returns to the original screen right away.	Faulty connection of the remote controller transmission cable	Check the items described in (1) ②.
		When PZ-61DR-E is used, the group wiring and the group setting of the system controller do not match.	Check the group wiring or the group setting of the system controller.
		The Lossnay unit, which is set as the main Lossnay (SW5-10 ON), is not set to the address with the smallest number in the group.	Set the Lossnay unit, which is set as the main Lossnay (SW5-10 ON) to the address with the smallest number. (See the Lossnay technical manual.)

(4) Failure mode 4: Lossnay does not work properly.

● Initial Check Items

If Lossnay does not work properly after installation is completed, check the following items.

No.	Check item	Notes
1	Are the function selection switches (SW2 and SW5) on the Lossnay circuit board set correctly to suit the required application?	Depending on the settings of the function selection switches, Lossnay may automatically operate or stop, or specific operation may be unable to be performed with the remote controller.
2	When PZ-61DR-E is used, are the function selections set correctly to suit the required application?	Depending on the settings of the function selections, Lossnay may automatically operate or stop, or specific operation may be unable to be performed with the remote controller.
3	When PZ-61DR-E is used, are icons and characters displayed on the PZ-61DR-E screen?	Based on the icon and characters, you can check statuses such as the timer operation, Night-purge, and protective operation. (See the Lossnay technical manual.)
4	Is the system controller of M-NET used?	The system controller can be used to start/stop Lossnay, change fan speed or ventilation mode, and prohibit the start/stop operation by PZ-61DR-E.
5	Is the external input used?	If the interlock mode is set to the "External input priority ON/OFF interlock" and if the external device is operating, the stop operation by PZ-61DR-E is prohibited. (See the Lossnay technical manual.) If the Remote/Local switching (CN32) is set to remote, the start/stop operation by the Lossnay remote controller is prohibited. (See the Lossnay technical manual.) Priority is given to the operation by the fan speed switching input and Bypass mode switching input. (CN17, CN26) (See the Lossnay technical manual.)

● Individual check items

If Lossnay does not work after installation is completed, check the following items.

No.	Problem	Factor	Corrective action
1	Actual fan speed of the Lossnay unit differs from the fan speed set with the remote controller.	The signal is input to the fan speed input (CN17).	Check the fan speed input (CN17). (See the Lossnay technical manual.)
		The signal is input to the fan speed switching input (CN26 ④ ⑤).	Check the fan speed switching input (CN26 ④ ⑤). (See the Lossnay technical manual.)
		Function setting (No. 8) of PZ-61DR-E "Max. fan speed setting during the first 30 minutes" is enabled.	Lossnay operates at fan speed 4 for 30 minutes when operation starts. (See the Lossnay technical manual.)
		The indoor negative pressure setting or the indoor positive pressure setting is set.	Check the function selection switches (SW2-4 and 2-5) on the circuit board or the function settings (No. 6 and 7) of PZ-61DR-E. (See the Lossnay technical manual.)
		The system is operating in the protective mode (intermittent operation).	When PZ-61DR-E is used, it displays the icon "⚠" that indicates the protective operation is in-progress. For details, see the Lossnay technical manual or remote controller manual.
	The pre-heater is ON.	When the pre-heater is ON, Lossnay runs at fan speed 2 or higher speed. Even when fan speed 1 is selected with the remote controller or external fan speed input, Lossnay runs at fan speed 2.	

No.	Problem	Factor	Corrective action
2	Even though the remote controller is operated to change the ventilation mode, the ventilation mode is not changed.	The outdoor temperature is 8°C or lower.	When the outdoor temperature is 8°C or lower, the ventilation mode is fixed to the Energy recovery mode.
		The signal is input to the Bypass mode switching input (CN26 ① ②).	Check the Bypass mode switching input (CN26 ① ②). (See the Lossnay technical manual.)
		The Lossnay unit is performing the Night-purge operation.	The ventilation mode cannot be changed during the Night-purge operation. (See the Lossnay technical manual.)
		The pre-heater is ON, or within one hour after the pre-heater is turned OFF.	When the pre-heater is ON, or for one hour after the pre-heater is turned OFF, the ventilation mode is fixed to the Energy recovery mode.
3	The Night-purge operation cannot be stopped with PZ-61DR-E.	Usual start/stop button operation cannot stop the Night-purge operation.	Press the start/stop button once to display the operation screen, and then press the start/stop button again.
4	Even though the Night-purge is set, Lossnay does not perform the Night-purge operation.	Conditions of the Night-purge are not satisfied.	When the Night-purge conditions such as the indoor/outdoor temperature are not satisfied, Lossnay does not perform the Night-purge operation. For details, see the Lossnay technical manual.
		The Night-purge schedule is not set.	Check the setting of PZ-61DR-E or the system controller that supports Night-purge operation. For details, see the Lossnay technical manual.
5	The Night-purge operation stops in halfway through.	The operating condition became outside the Night-purge conditions.	When the operating condition becomes outside the Night-purge conditions, the Night-purge operation ends. For details, see the Lossnay technical manual.
		The Lossnay remote controller or the system controller was operated to start or stop the operation of the Lossnay unit.	When the start or stop operation is performed during the Night-purge operation, the Night-purge operation ends.
		A controller other than PZ-61DR-E or a controller that is not supporting Night-purge is operated to change the ventilation mode.	When a controller other than those supporting Night-purge is operated to change the ventilation mode, the system performs the normal ventilating operation. (See the Lossnay technical manual.)

(5) Failure mode 5: Error code and LED display

An error code displayed on the remote controller (PZ-61DR-E, PZ-43SMF-E) or the M-NET controller, and blinking or illumination of LED1 (green) or LED2 (red) on the circuit board show the type of an error. The LED blink interval is 0.25 seconds for both on and off. The display duration is approximately 7 seconds.

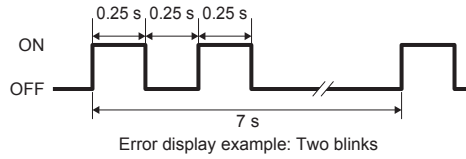

Error display list

Error Code	LED1 (green)	LED2 (red)	Symptom	Cause	Corrective action
0900	—	—	Trial operation	The trial operation switch (SW2-1) on the circuit board is set to "ON".	Check the trial operation switch. (See the Lossnay technical manual.)
3126	8 blinks	—	External device error	When the terminals (TM3 ⑦⑩) are set for pre-heater output (function selection switch (SW5-6) on the circuit board is ON, or the function setting (No. 58) of PZ-61DR-E set to "2"), the following conditions were satisfied. <ul style="list-style-type: none"> • Outdoor air temperature detected by OA thermistor stays at 70°C or higher for one minute. • Outdoor air temperature detected by OA thermistor exceeds 15°C within 15 minutes after the pre-heater output starts. • Outdoor air temperature is still -10°C or lower one hour after the pre-heater output starts. Causes of the above phenomena are described below.	See below.
				The pre-heater is connected to the wrong terminal.	Connect the pre-heater to the terminals (TM3 ⑦⑩). (See the Lossnay technical manual.)
				Faulty connection of the pre-heater	Check the pre-heater connections.
				The output capacity of the pre-heater is too large with respect to the air volume of the Lossnay unit.	Adjust the output capacity of the pre-heater. When the pre-heater is used, run the Lossnay at a higher fan speed.
				The output capacity of the pre-heater is too small with respect to the air volume of the Lossnay unit.	Adjust the output capacity of the pre-heater. When the pre-heater is used, run the Lossnay at a lower fan speed.
				Even though the pre-heater is in use, the function selection switch (SW5-6) on the circuit board is not set to ON, or the function setting (No. 58) of PZ-61DR-E is not set to "2".	Check the setting of the function selection switch (SW5-6) on the circuit board or the function setting (No. 58) of PZ-61DR-E. (See the Lossnay technical manual.)
				Even though the pre-heater is not in use, the function selection switch (SW5-6) on the circuit board is set to ON, or the function setting (No. 58) of PZ-61DR-E is set to "2".	
				Pre-heater failure	Replace the pre-heater.
				Pre-heater relay failure	Replace the relay for the pre-heater.
Circuit board failure	Replace the circuit board.				

Error Code	LED1 (green)	LED2 (red)	Symptom	Cause	Corrective action
4101	11 blinks	—	Overcurrent error of the remote controller terminal	Shorting between remote controller terminals	Check the remote controller wiring.
				In one group, two or more Lossnay units are set as the main Lossnay (SW5-10 ON).	Only one Lossnay unit can be set as the main Lossnay in one group. (See the Lossnay technical manual.)
				M-NET transmission cable is connected to the remote controller terminal block (TM4 ① ②).	Connect the M-NET transmission cable to the M-NET transmission cable terminal block (TB5 [A] [B]).
				Three or more remote controllers are connected.	Up to two remote controllers can be connected.
				Circuit board failure	Replace the circuit board.
				Remote controller failure	Replace the remote controller.
4116	1 blink	—	Abnormal rotation of the supply fan motor (in the lower unit for LGH-150RVX-E and LGH-200RVX-E) (Centrifugal fan does not work, insufficient motor speed, excessive motor speed, or rotation detected when operation is stopped)	Faulty connection of the supply fan motor connector (CN10) on the power circuit board	Check the connector (CN10) connection.
				Faulty connection of the connectors (CN18 - CN118 and CN19 - CN119) between the control circuit board and power circuit board	Check the connector connections (CN18 - CN118 and CN19 - CN119).
				The model selection switch (SW6) is not set correctly.	Make the SW6 setting appropriate for the model. (See chapter 7. (8) Setting status record (page 46).)
				The temperature around the product is high.	Use the product at a temperature of 40°C or lower.
				The motor and centrifugal fan are not fixed securely.	Check the installation state of the motor and centrifugal fan, and fix them securely.
				Deformed centrifugal fan	Replace the centrifugal fan.
				Foreign objects around the centrifugal fan	Check the air course and around the centrifugal fan, and remove any foreign matter.
				Fan motor failure	Replace the fan motor. (See page 18.)
				Circuit board failure	Replace the circuit board.
	2 blinks	—	Abnormal rotation of the exhaust fan motor (in the lower unit for LGH-150RVX-E and LGH-200RVX-E) (Centrifugal fan does not work, insufficient motor speed, excessive motor speed, or rotation detected when operation is stopped)	Faulty connection of the exhaust fan motor connector (CN9) on the power circuit board	Check the connector (CN9) connection.
				Faulty connection of the connectors (CN18 - CN118 and CN19 - CN119) between the control circuit board and power circuit board	Check the connector connections (CN18 - CN118 and CN19 - CN119).
				The model selection switch (SW6) is not set correctly.	Make the SW6 setting appropriate for the model. (See chapter 7. (8) Setting status record (page 46).)
				The temperature around the product is high.	Use the product at a temperature of 40°C or lower.
				The motor and centrifugal fan are not fixed securely.	Check the installation state of the motor and centrifugal fan, and fix them securely.
				Deformed centrifugal fan	Replace the centrifugal fan.
				Foreign objects around the centrifugal fan	Check the air course and around the centrifugal fan, and remove any foreign matter.
				Fan motor failure	Replace the fan motor. (See page 18.)
				Circuit board failure	Replace the circuit board.

Error Code	LED1 (green)	LED2 (red)	Symptom	Cause	Corrective action
4116	6 blinks	—	(Only for LGH-150RVX-E and LGH-200RVX-E) Abnormal rotation of the supply fan motor in the upper unit (Centrifugal fan does not work, insufficient motor speed, excessive motor speed, or rotation detected when operation is stopped)	Faulty connection of the supply fan motor connector (CN10) on the power circuit board (upper)	Check the connector (CN10) connection on the power circuit board (upper).
				Faulty connection of the connectors (CN18 - CN118, CN19 - CN119, and CN21 - CN121) between the control circuit board and power circuit board	Check the connectors connections (CN18 - CN118, CN19 - CN119, and CN21 - CN121).
				Faulty connection of the reactor connectors (TB3 and TB4) on the power circuit board (upper)	Check the connector (TB3 and TB4) connections on the power circuit board (upper).
				The model selection switch (SW6) is not set correctly.	Make the SW6 setting appropriate for the model. (See chapter 7. (8) Setting status record (page 46).)
				The temperature around the product is high.	Use the product at a temperature of 40°C or lower.
				The motor and centrifugal fan are not fixed securely.	Check the installation state of the motor and centrifugal fan, and fix them securely.
				Deformed centrifugal fan	Replace the centrifugal fan.
				Foreign objects around the centrifugal fan	Check the air course and around the centrifugal fan, and remove any foreign matter.
				Fan motor failure	Replace the fan motor. (See page 18.)
	Circuit board failure	Replace the circuit board.			
	7 blinks	—	(Only for LGH-150RVX-E and LGH-200RVX-E) Abnormal rotation of the exhaust fan motor in the upper unit (Centrifugal fan does not work, insufficient motor speed, excessive motor speed, or rotation detected when operation is stopped)	Faulty connection of the exhaust fan motor connector (CN9) on the power circuit board (upper)	Check the connector (CN9) connection on the power circuit board (upper).
				Faulty connection of the connectors (CN18 - CN118, CN19 - CN119, and CN21 - CN121) between the control circuit board and power circuit board	Check the connectors connections (CN18 - CN118, CN19 - CN119, and CN21 - CN121).
				Faulty connection of the reactor connectors (TB3 and TB4) on the power circuit board (upper)	Check the connector (TB3 and TB4) connections on the power circuit board (upper).
				The model selection switch (SW6) is not set correctly.	Make the SW6 setting appropriate for the model. (See chapter 7. (8) Setting status record (page 46).)
				The temperature around the product is high.	Use the product at a temperature of 40°C or lower.
				The motor and centrifugal fan are not fixed securely.	Check the installation state of the motor and centrifugal fan, and fix them securely.
				Deformed centrifugal fan	Replace the centrifugal fan.
Foreign objects around the centrifugal fan				Check the air course and around the centrifugal fan, and remove any foreign matter.	
Fan motor failure	Replace the fan motor. (See page 18.)				
Circuit board failure	Replace the circuit board.				

Error Code	LED1 (green)	LED2 (red)	Symptom	Cause	Corrective action
5101	4 blinks	—	Outdoor air (OA) thermistor related error	Faulty connection of the thermistor connector (CN22) on the control circuit board	Check the connector (CN22) connection.
				Thermistor failure	Disconnect the connector (CN22), and check the resistance of the thermistor. If the equivalent thermistor resistance differs greatly from the ambient temperatures, replace the thermistor. (See (6) Temperatures and thermistor resistance table (page 35).)
5102	5 blinks	—	Indoor air (RA) thermistor related error	Faulty connection of the thermistor connector (CN5) on the control circuit board	Check the connector (CN5) connection.
				Thermistor failure	Disconnect the connector (CN5), and check the resistance of the thermistor. If the equivalent thermistor resistance differs greatly from the ambient temperatures, replace the thermistor. (See (6) Temperatures and thermistor resistance table (page 35).)
6600	—	6 blinks	Multiple address error	The system contains two or more units (*1) set with the same address in the same M-NET transmission cable line.	Find the units (*1) set with the same address, and set unique addresses to these units.
6602	—	2 blinks	Transmission error (transmission processor hardware error)	Faulty connection of the M-NET transmission cable	Check the items described in (1) ②.
				<ul style="list-style-type: none"> • Wiring was performed with power still supplied to the M-NET transmission cable. • Accidental communication error 	Restart the system after completing wiring. If the error re-occurs, check for noise on the transmission cable. If the above does not correct the problem, replace the Lossnay circuit board.
				Power is supplied to the same transmission cable from two or more power supply units. The power supply unit is connected to the TB3 terminal of the transmission booster.	Check the wiring of the power supply unit and the transmission booster.
				PZ-61DR-E is connected to the terminals (TB5 [A] [B]).	Connect PZ-61DR-E to the terminals (TM4 ① ②). (See the Lossnay technical manual.)
				Malfunction of the unit (*1) where an error occurs	Check the unit (*1) where the error occurs.

*1 This refers to devices assigned an address number in MELANS such as the Lossnay unit, City Multi indoor unit, City Multi outdoor unit, or system controller.

Error Code	LED1 (green)	LED2 (red)	Symptom	Cause	Corrective action
6603	—	5 blinks	Transmission error (transmission bus busy)	Faulty connection of the M-NET transmission cable	Check the items described in (1) ②.
				<ul style="list-style-type: none"> • Wiring was performed with power still supplied to the M-NET transmission cable. • Accidental communication error 	Restart the system after completing wiring. If the error re-occurs, check for noise on the transmission cable. If the above does not correct the problem, replace the Lossnay circuit board.
				Power is supplied to the same transmission cable from two or more power supply units. The power supply unit is connected to the TB3 terminal of the transmission booster.	Check the wiring of the power supply unit and the transmission booster.
				PZ-61DR-E is connected to the terminals (TB5 [A] [B]).	Connect PZ-61DR-E to the terminals (TM4 ① ②). (See the Lossnay technical manual.)
			Malfunction of the unit (*1) where an error occurs	Check the unit (*1) where the error occurs.	
6606	—	3 blinks	Transmission/reception error (communication error with transmission processor)	Faulty connection of the M-NET transmission cable	Check the items described in (1) ②.
				<ul style="list-style-type: none"> • Wiring was performed with power still supplied to the M-NET transmission cable. • Accidental communication error 	Restart the system after completing wiring. If the error re-occurs, check for noise on the transmission cable. If the above does not correct the problem, replace the Lossnay circuit board.
				Malfunction of the unit (*1) where an error occurs	Check the unit (*1) where the error occurs.
6607	—	8 blinks	Transmission/reception error (no ACK error)	The power of the Lossnay unit is not ON.	Check the power of the Lossnay unit.
				The Lossnay address was changed.	Check the Lossnay address.
				PZ-61DR-E is connected to the terminals (TB5 [A] [B]).	Connect PZ-61DR-E to the terminals (TM4 ① ②). (See the Lossnay technical manual.)
6608	—	8 blinks	Transmission/reception error (no response error)	Multiple M-NET transmission cables are wired using multicore cables.	Using the applicable cable, wire the transmission cable away from one another.
				The M-NET transmission cable is not securely connected.	Check the transmission cable connections.
				The wiring length of the M-NET transmission cable is longer than specified. (Longer than 200 m from the power supply unit, longer than 500 m in total length)	Check the wiring length of the transmission cable.
				PZ-61DR-E is connected to the terminals (TB5 [A] [B]).	Connect PZ-61DR-E to the terminals (TM4 ① ②). (See the Lossnay technical manual.)

*1 This refers to devices assigned an address number in MELANS such as the Lossnay unit, City Multi indoor unit, City Multi outdoor unit, or system controller.

Error Code	LED1 (green)	LED2 (red)	Symptom	Cause	Corrective action
6801	9 blinks	—	PZ-43SMF-E communication error	Multiple PZ-43SMF-E transmission cables are wired using multicore cables.	Using the applicable cable, wire the transmission cable away from one another.
				The power supply cable is too close to the PZ-43SMF-E transmission cable.	Wire the power supply cable at least 5 cm away from the transmission cable.
				Faulty connection of the PZ-43SMF-E transmission cable	Check the transmission cable connections.
				The wiring length of the PZ-43SMF-E transmission cable is longer than specified (200 m or more).	Check the wiring length of the transmission cable.
				The Lossnay is used in the same group as LGH-RX5-E type Lossnay.	The LGH-RVX-E type Lossnay cannot be used in the same group as LGH-RX5-E type Lossnay.
				PZ-43SMF-E is connected to the terminals (TB5 [A] [B]).	Connect PZ-43SMF-E to the terminals (TM4 ① ②). (See the Lossnay technical manual.)
6831	9 blinks	—	PZ-61DR-E communication error (no reception)	Faulty connection of the PZ-61DR-E transmission cable	Check the items described in (1) ②. If the error re-occurs, check for noise on the transmission cable. If the above does not correct the problem, replace the Lossnay circuit board or PZ-61DR-E remote controller.
				The Lossnay is used in the same group as LGH-RX5-E type Lossnay.	The LGH-RVX-E type Lossnay cannot be used in the same group as LGH-RX5-E type Lossnay.
				PZ-61DR-E is connected to the terminals (TB5 [A] [B]).	Connect PZ-61DR-E to the terminals (TM4 ① ②). (See the Lossnay technical manual.)
6832	9 blinks	—	PZ-61DR-E communication error (synchronization recovery error)	Faulty connection of the PZ-61DR-E transmission cable	Check the items described in (1) ②. If the error re-occurs, check for noise on the transmission cable. If the above does not correct the problem, replace the Lossnay circuit board or PZ-61DR-E remote controller.
				The Lossnay is used in the same group as LGH-RX5-E type Lossnay.	The LGH-RVX-E type Lossnay cannot be used in the same group as LGH-RX5-E type Lossnay.
6833	9 blinks	—	PZ-61DR-E communication error (hardware error)	Faulty connection of the PZ-61DR-E transmission cable	Check the items described in (1) ②. If the error re-occurs, check for noise on the transmission cable. If the above does not correct the problem, replace the Lossnay circuit board or PZ-61DR-E remote controller.
				The Lossnay is used in the same group as LGH-RX5-E type Lossnay.	The LGH-RVX-E type Lossnay cannot be used in the same group as LGH-RX5-E type Lossnay.

Error Code	LED1 (green)	LED2 (red)	Symptom	Cause	Corrective action
6834	9 blinks	—	PZ-61DR-E communication error (start bit detection error)	Faulty connection of the PZ-61DR-E transmission cable	Check the items described in (1) ②. If the error re-occurs, check for noise on the transmission cable. If the above does not correct the problem, replace the Lossnay circuit board or PZ-61DR-E remote controller.
				The Lossnay is used in the same group as LGH-RX ₅ -E type Lossnay.	The LGH-RVX-E type Lossnay cannot be used in the same group as LGH-RX ₅ -E type Lossnay.
7113	10 blinks	—	Function setting error	In one group, two or more Lossnay units are set as the main Lossnay (SW5-10 ON).	Only one Lossnay unit can be set as the main Lossnay in one group. (See the Lossnay technical manual.)
				The group contains two or more Lossnay units set with the same address.	Set unique addresses to these units.
				The Lossnay unit, which is set as the main Lossnay (SW5-10 ON), is not set to the address with the smallest number in the group.	Set the Lossnay unit, which is set as the main Lossnay (SW5-10 ON) to the address with the smallest number. (See the Lossnay technical manual.)
				The MA remote controller for the air conditioner (Mr. Slim indoor unit or City Multi indoor unit) is connected.	Replace the remote controller with PZ-61DR-E.
				The remote controller terminals (TM4 ①②) of the Lossnay unit and the remote controller terminals of the City Multi indoor unit are connected together within the group.	Assign the Lossnay units and City Multi indoor units to the different groups.
				The Lossnay is used in the same group as LGH-RX ₅ -E type Lossnay.	The LGH-RVX-E type Lossnay cannot be used in the same group as LGH-RX ₅ -E type Lossnay.
				The model selection switch (SW6) is not set correctly.	Make the SW6 setting appropriate for the model. (See chapter 7. (8) Setting status record (page 46).)

(6) Temperatures and thermistor resistance table

Temperature (°C)	Resistance value (kΩ)	Temperature (°C)	Resistance value (kΩ)	Temperature (°C)	Resistance value (kΩ)	Temperature (°C)	Resistance value (kΩ)	Temperature (°C)	Resistance value (kΩ)
-30	53.9 to ∞	-7	18.0	8	9.5	23	5.4	38	3.1
⋮	⋮	-6	17.2	9	9.2	24	5.1	39	3.1
-20	32.8	-5	16.5	10	8.8	25	5.0	40	3.0
-19	31.2	-4	15.7	11	8.5	26	4.8	41	2.8
-18	29.8	-3	15.1	12	8.1	27	4.7	42	2.7
-17	28.4	-2	14.5	13	7.8	28	4.5	43	2.7
-16	27.1	-1	13.8	14	7.6	29	4.3	44	2.6
-15	25.8	0	13.3	15	7.3	30	4.2	45	2.5
-14	24.7	1	12.8	16	7.0	31	4.0	46	2.4
-13	23.6	2	12.2	17	6.7	32	3.9	47	2.3
-12	22.5	3	11.7	18	6.5	33	3.7	48	2.2
-11	21.5	4	11.2	19	6.3	34	3.6	49	2.2
-10	20.6	5	10.7	20	6.0	35	3.5	50	2.1
-9	19.7	6	10.3	21	5.8	36	3.4	⋮	⋮
-8	18.8	7	10.0	22	5.6	37	3.2	90	0 to 0.7

* Measure the indoor air (RA) thermistor resistance across pin No. 1 and 2 of CN5, and the outdoor air (OA) thermistor resistance across pin No. 1 and 2 of CN22.

(7) Motor resistance table

⚠ Cautions:

- Before disconnecting the motor connectors, make sure that the power is turned OFF and the circuit board is discharged adequately.
- Even after the power supply is cut off, the capacitor is charged. Therefore, high voltage is applied to the motor for a while. Make sure that the LEDs on the circuit board are turned OFF before starting work.
- Never touch the circuit board while the power is ON. It causes electric shock and failure of the unit.

Replace the fan motor in the following cases.

- ① If it is hard to rotate the motor shaft by hand
- ② If the resistance between the motor leads is significantly different from the values specified in the table below

*Before measuring the resistance, the motor connectors must be disconnected from the circuit board.

LGH-15RVX-E, LGH-25RVX-E, LGH-35RVX-E, LGH-50RVX-E, LGH-65RVX-E				
Lead color	Black-Red	Black-White	Black-Yellow	Black-Brown
Normal resistance	About 450 kΩ	About 40 kΩ	About 90 kΩ	∞ kΩ

LGH-80RVX-E, LGH-100RVX-E, LGH-150RVX-E, LGH-200RVX-E				
Lead color	Black-Red	Black-White	Black-Yellow	Black-Blue
Normal resistance	∞ kΩ	About 50 kΩ	About 150 kΩ	∞ kΩ

7. Overhauling procedures

■ Work precautions

- When touching the electric components such as circuit boards and fan motors, do not touch the components for more than 5 minutes after power-off, and then start working. If LED4 on the circuit board is lit, do not touch the electric components.
- Before replacing parts, repair troubled sections according to the instructions described in the troubleshooting.
- When servicing, always keep proper footing.
- When servicing, always turn off the power supply isolator. Pay sufficient attention to avoid electrical shock or injury.
- Always connect the power wire properly.
- After completing repairs, check that the unit operates properly.
- Always wear gloves when servicing.

(1) Turning power off

- ① Shut down the unit.
- ② Turn off the power supply isolator.

(2) Fan parts

- ① Unscrew the black screws (three special (spl) screws 4×8, indicated by ○) to remove the control cover.



Serial number

- ② Check that LED4 on the circuit board is OFF, and then disconnect the motor connectors (indicated by ○) from the power circuit board.

Assembly precaution
After connecting the motor connectors, tuck the excess leads into the main unit.



Power circuit board

- ③ Unscrew the black screw (one spl screw 4×8, indicated by ○) for the fix piece.



Fix piece

④ Slide the fix piece to the left side.

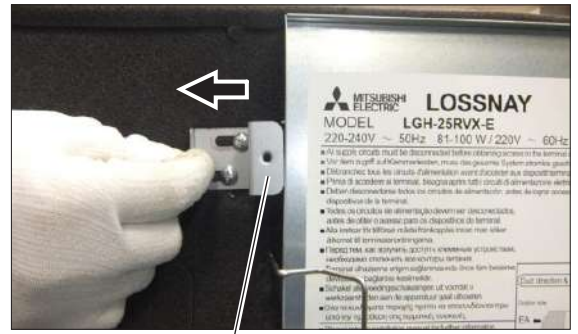

Fix piece

⑤ Pull out the hinge, and open the maint. (maintenance) cover.



Hinge

Maint. cover

⑥ Draw the Lossnay cores (with filters) from the main unit.

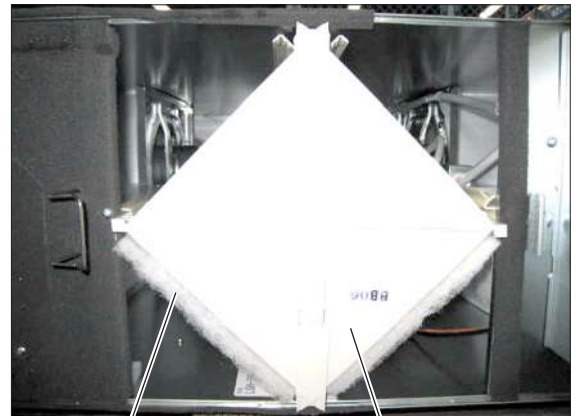

Filter

Lossnay core

⑦ Unscrew the screws (one spl screw M4 for each core guide, indicated by ○), and remove the core guides (left (L) and right (R)).



Core guide L

⑧ Take off the separators.



Separator

⑨ Unscrew the screws (indicated by \triangle), and remove the motor fix plate.

For LGH-15RVX-E and LGH-25RVX-E

(Four PTT screws 4×10, indicated by \triangle)

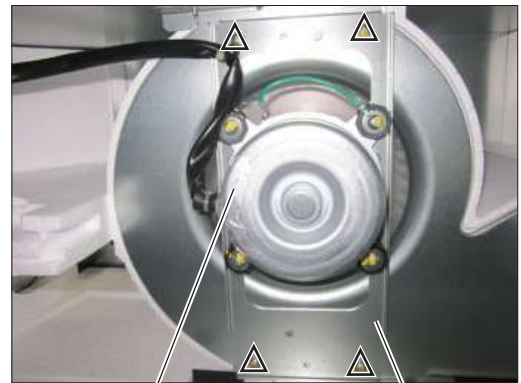

Motor

Motor fix plate

For LGH-35RVX-E and LGH-50RVX-E

(Six PTT screws 5×10, indicated by \triangle)

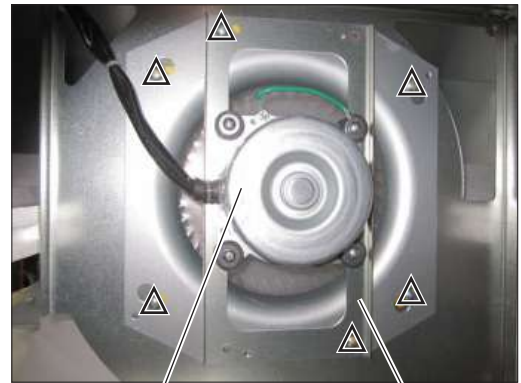

Motor

Motor fix plate

For LGH-65RVX-E to LGH-200RVX-E

(Six PTT screws 5×10, indicated by \triangle)

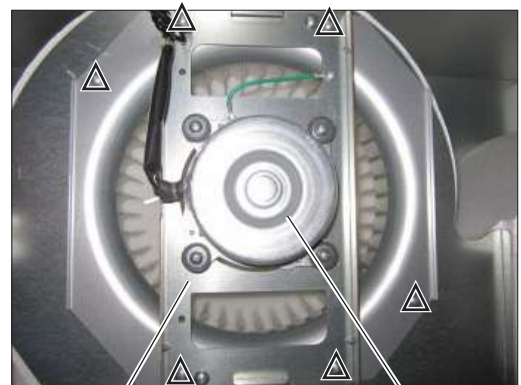

Motor fix plate

Motor

(3) Terminal block parts

- ① Remove the control cover. → See (2) ①.
- ② Check that LED4 on the circuit board is OFF, and then disconnect the connectors (indicated by ○) from the power circuit board.

Power circuit board



- ③ Unscrew the screw (one PT screw 4×8 (BS), indicated by ○) and the lock washer (4).
- ④ Unscrew the screws (one PT screw 4×8 indicated by △ and one PPT screw 4×20 indicated by □), and remove the lead assembly with the terminal block.

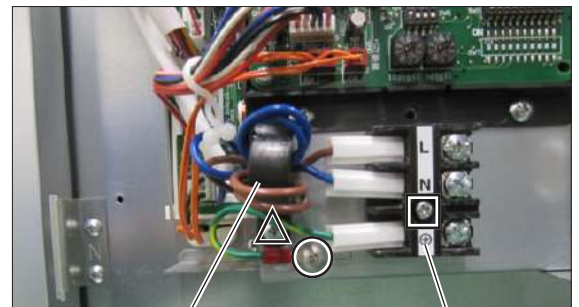

Lead assembly

Terminal block

(4) Control parts (For LGH-15RVX-E to LGH-100RVX-E)

Precaution

Before replacing the circuit boards, see (6) Procedures for replacing the circuit boards (on pages 43 to 45).

- ① Remove the control cover. → See (2) ①.
- ② Check that LED4 on the circuit board is OFF, and then disconnect the connectors (indicated by ○) from the control circuit board.



Control circuit board

- ③ Unscrew the screws (two PT screws 4×8, indicated by ○), and remove the control circuit board.



Control circuit board

- ④ Disconnect the connectors (indicated by ○) from the power circuit board.

Assembly precaution
After connecting the motor connectors, tuck the excess leads into the main unit.

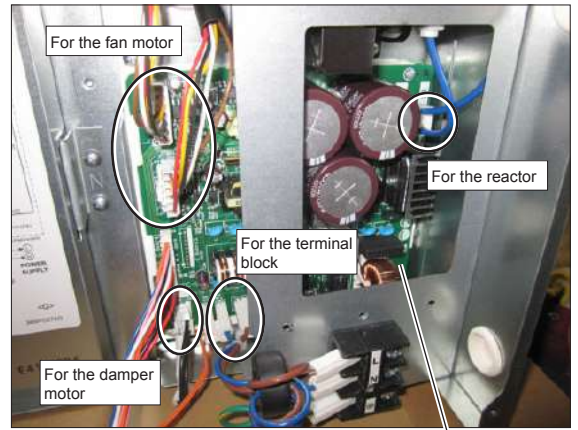
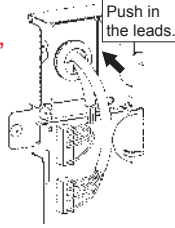

Power circuit board

- ⑤ Unscrew the earth fixing screw (one PT screw 4×8 (BS), indicated by ○).

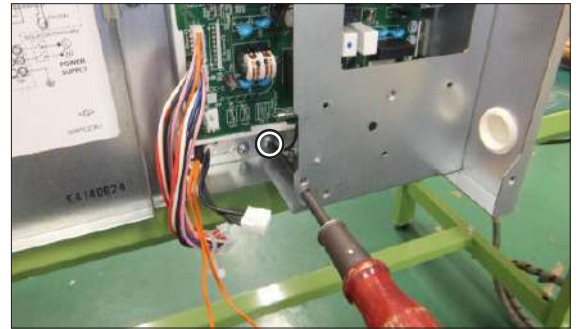

- ⑥ Unscrew the screw (one PT screw 4×8, indicated by ○), and remove the power circuit board.

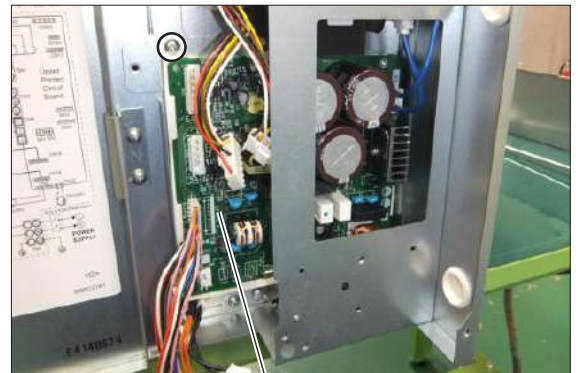

Power circuit board

- ⑦ Unscrew the screws (four PTT screws 4×8, indicated by ○), and remove the control unit from the main unit.



Control unit



⑧ Unscrew the screws (three PT screws 4×8, indicated by ○) to remove the control base.

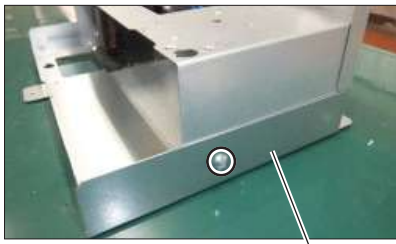

Control base

⑨ Unscrew the screws (two PT screws 4×8, indicated by ○), and remove the reactor.

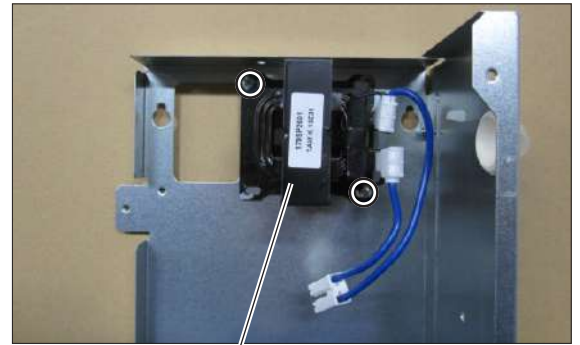

Reactor

(5) Control parts (For LGH-150RVX-E and LGH-200RVX-E)

Precaution

Before replacing the circuit boards, see (6) Procedures for replacing the circuit boards (on pages 43 to 45).

● When removing only the control circuit board

① Unscrew the black screws (three spl screws 4×8, indicated by ○) to remove the cover plate.



Cover plate

② Check that LED4 on the circuit board is OFF, and then disconnect the connectors (indicated by ○) from the control circuit board.

③ Unscrew the screws (two PT screws 4×8, indicated by △), and remove the control circuit board.



Control circuit board

● **When removing the power circuit boards or reactors**

- ① Unscrew the screws (eight PT screws 4×8, indicated by ○) to remove the control cover.



- ② Remove the circuit boards and reactors.

[Upper unit]

- a. Disconnect the connectors (indicated by ○).

Assembly precaution
After connecting the motor connectors, tuck the excess leads into the main unit.

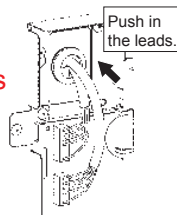

- b. Unscrew the screws (one PT screw 4×8, indicated by △, one PT screw 4×8 (BS), indicated by □), and remove the power circuit board (upper).
c. Unscrew the screws (two PT screws 4×8, indicated by ◇), and remove the reactor.

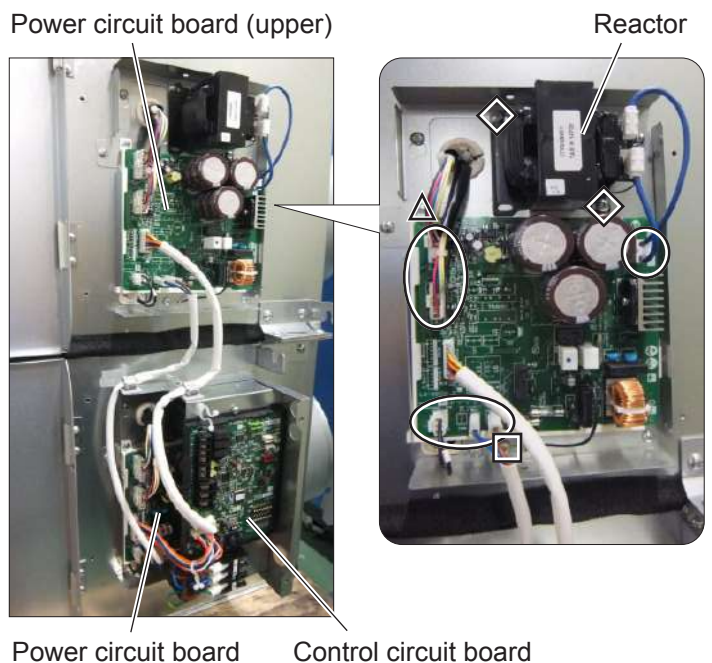

[Lower unit]

- a. Remove the control circuit board. → See (5) ② and ③ (on page 41).
b. Remove the power circuit board. → See (4) ④ to ⑥ (on page 40).
c. Remove the reactor. → See (4) ⑦ to ⑨ (on pages 40 and 41).

*** When reassembling**

- Reassemble the unit in the reverse order of disassembly.
- After reassembly, always make a test run to be sure that the unit operates properly.

(6) Procedures for replacing the circuit boards

Notes

- Before removing the circuit boards for replacement, check the following Steps 1 and 2.
- When the Lossnay remote controller PZ-61DR-E is connected, make sure to replace the circuit boards as described in the Steps.

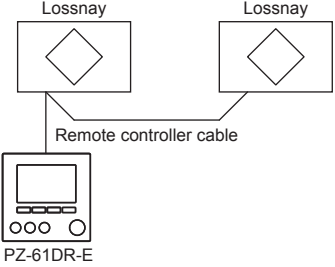
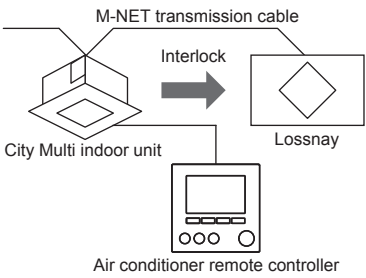
Step	Details	Check item	
1	Check the system configuration.		
	Check if PZ-61DR-E is connected to the circuit board to be replaced.	PZ-61DR-E connection	
	The following describes settings required when replacing the circuit boards per the system configuration. Check which system configuration is applicable, and then replace the circuit boards.	System Configuration	
	<div style="display: flex; justify-content: space-between;"> <div data-bbox="260 595 683 860" style="width: 45%;"> <p>(A)</p>  <p>Lossnay Lossnay</p> <p>Remote controller cable</p> <p>PZ-61DR-E</p> </div> <div data-bbox="834 595 1444 719" style="width: 50%;"> <p>① Setting of the function selection switches on the circuit board. ② Setting of the PZ-61DR-E functions. ③ Address setting (when M-NET is used).</p> <p style="text-align: right;">➔ Go to Step 2.</p> </div> </div> <hr style="border-top: 1px dashed black;"/> <div style="display: flex; justify-content: space-between;"> <div data-bbox="260 891 683 1167" style="width: 45%;"> <p>(B)</p>  <p>M-NET transmission cable</p> <p>Interlock</p> <p>City Multi indoor unit Lossnay</p> <p>Air conditioner remote controller</p> </div> <div data-bbox="834 891 1444 992" style="width: 50%;"> <p>① Setting of the function selection switches on the circuit board. ② Address setting.</p> <p style="text-align: right;">➔ Go to Step 3.</p> </div> </div>		
2	<p>Check the settings on PZ-61DR-E.</p> <p>Regarding the settings on PZ-61DR-E, prepare the data recorded at the time of installation (setting status record, etc.).</p> <p>In the case there is no data recorded at the time of installation, and if the Lossnay unit can be operated with PZ-61DR-E, use the form in "(8) Setting status record" (page 46) to record the settings on PZ-61DR-E.</p> <p>To check the settings on PZ-61DR-E, see the Lossnay technical manual or remote controller manual.</p> <ul style="list-style-type: none"> • On the function setting screen of PZ-61DR-E, display the M-NET address of the Lossnay unit for which you wish to check the settings. • The address can be checked by the address setting switches (SA1 and SA2) on the Lossnay circuit board. 	Setting status record	
3	<p>Setting status record of the address setting switches and function selection switches on the circuit board</p> <p>Using the form in "(8) Setting status record" (page 46), record setting statuses necessary for replacing the circuit board.</p> <p>Remove the control box cover, and check the setting status of each switch on the circuit board.</p> <p>If the function setting statuses were recorded at the time of installation, this step can be skipped.</p> <ol style="list-style-type: none"> ① Address setting (SA1 and SA2) ② Function selection switches and model selection switch setting (SW2, SW5, and SW6) ③ External input (as necessary, record the connection status) 	Setting status record	

Step	Details	Check item																																																																
4	<p>Removing the circuit boards</p> <ul style="list-style-type: none"> For the working precautions, see page 36. For removing the circuit boards, see (4) Control parts (For LGH-15RVX-E to LGH-100RVX-E) (page 39) or (5) Control parts (For LGH-150RVX-E and LGH-200RVX-E) (page 41). 																																																																	
5	<p>Attaching the circuit boards</p> <p>① According to the function status record data prepared in Step 3, set the address setting switches, function selection switches, and model selection switch of the new circuit board.</p> <p>a. Address setting (SA1 and SA2)</p> <p>b. Function selection switches and model selection switch setting (SW2, SW5, and SW6)</p> <p>② Attach the power circuit board in the reverse order of the steps for removing. Make sure to connect the connectors listed in the following table.</p> <table border="1"> <thead> <tr> <th>Connector</th> <th>Symbol on the circuit board</th> <th>Check</th> </tr> </thead> <tbody> <tr> <td>For power supply connection</td> <td>TAB1, TAB2, TAB5*</td> <td></td> </tr> <tr> <td>For reactor connection</td> <td>TAB3, TAB4</td> <td></td> </tr> <tr> <td>For exhaust fan motor connection</td> <td>CN9</td> <td></td> </tr> <tr> <td>For supply fan motor connection</td> <td>CN10</td> <td></td> </tr> <tr> <td>For damper motor connection</td> <td>CN7</td> <td></td> </tr> <tr> <td>For control circuit board connection</td> <td>CN118, CN119, CN121*</td> <td></td> </tr> </tbody> </table> <p>* Only the LGH-150RVX-E and LGH-200RVX-E type Lossnay are equipped with TAB5 and CN121.</p> <p>③ Reattach the base of the control circuit board, and then attach the connectors, remote controller transmission cable, M-NET transmission cable, and external signal cable, etc. Make sure to connect the connectors or terminals listed in the following table. (Connect PZ-61DR-E transmission cable terminal, M-NET transmission cable terminal, and connector/terminal for external signal cable only when they are used.)</p> <table border="1"> <thead> <tr> <th>Connector and terminal</th> <th>Symbol on the circuit board</th> <th>Check</th> </tr> </thead> <tbody> <tr> <td>For thermistor connection (outdoor temperature (OA))</td> <td>CN22</td> <td></td> </tr> <tr> <td>For thermistor connection (indoor temperature (RA))</td> <td>CN5</td> <td></td> </tr> <tr> <td>For power circuit board connection</td> <td>CN18, CN19, CN21*</td> <td></td> </tr> <tr> <td>PZ-61DR-E transmission cable terminal</td> <td>TM4 ① ②</td> <td></td> </tr> <tr> <td>M-NET transmission cable terminal</td> <td>TB5 [A] [B]</td> <td></td> </tr> <tr> <td>For external signal cable connection</td> <td>TM2, TM3, CN17, CN26, CN32</td> <td></td> </tr> </tbody> </table> <p>* Only the LGH-150RVX-E and LGH-200RVX-E type Lossnay are equipped with CN21.</p> <p>④ Reattach the control box cover.</p> <ul style="list-style-type: none"> LGH-15RVX-E to LGH-100RVX-E type : Cover screw 3 pieces LGH-150RVX-E and LGH-200RVX-E type : Cover screw 8 pieces 	Connector	Symbol on the circuit board	Check	For power supply connection	TAB1, TAB2, TAB5*		For reactor connection	TAB3, TAB4		For exhaust fan motor connection	CN9		For supply fan motor connection	CN10		For damper motor connection	CN7		For control circuit board connection	CN118, CN119, CN121*		Connector and terminal	Symbol on the circuit board	Check	For thermistor connection (outdoor temperature (OA))	CN22		For thermistor connection (indoor temperature (RA))	CN5		For power circuit board connection	CN18, CN19, CN21*		PZ-61DR-E transmission cable terminal	TM4 ① ②		M-NET transmission cable terminal	TB5 [A] [B]		For external signal cable connection	TM2, TM3, CN17, CN26, CN32		<table border="1"> <tbody> <tr> <td>Address setting</td> <td></td> </tr> <tr> <td>Function setting</td> <td></td> </tr> <tr> <td>Model selection</td> <td></td> </tr> <tr> <td>Circuit board fixing screw (1 pc.)</td> <td></td> </tr> <tr> <td>Base fixing screw (1 pc.)</td> <td></td> </tr> <tr> <td>Earth fixing screw (1 pc.)</td> <td></td> </tr> <tr> <td>Connector connection</td> <td></td> </tr> <tr> <td>PZ-61DR-E transmission cable connection</td> <td></td> </tr> <tr> <td>M-NET transmission cable connection</td> <td></td> </tr> <tr> <td>External signal cable connection</td> <td></td> </tr> <tr> <td>Cover screw (black)</td> <td></td> </tr> </tbody> </table>	Address setting		Function setting		Model selection		Circuit board fixing screw (1 pc.)		Base fixing screw (1 pc.)		Earth fixing screw (1 pc.)		Connector connection		PZ-61DR-E transmission cable connection		M-NET transmission cable connection		External signal cable connection		Cover screw (black)	
Connector	Symbol on the circuit board	Check																																																																
For power supply connection	TAB1, TAB2, TAB5*																																																																	
For reactor connection	TAB3, TAB4																																																																	
For exhaust fan motor connection	CN9																																																																	
For supply fan motor connection	CN10																																																																	
For damper motor connection	CN7																																																																	
For control circuit board connection	CN118, CN119, CN121*																																																																	
Connector and terminal	Symbol on the circuit board	Check																																																																
For thermistor connection (outdoor temperature (OA))	CN22																																																																	
For thermistor connection (indoor temperature (RA))	CN5																																																																	
For power circuit board connection	CN18, CN19, CN21*																																																																	
PZ-61DR-E transmission cable terminal	TM4 ① ②																																																																	
M-NET transmission cable terminal	TB5 [A] [B]																																																																	
For external signal cable connection	TM2, TM3, CN17, CN26, CN32																																																																	
Address setting																																																																		
Function setting																																																																		
Model selection																																																																		
Circuit board fixing screw (1 pc.)																																																																		
Base fixing screw (1 pc.)																																																																		
Earth fixing screw (1 pc.)																																																																		
Connector connection																																																																		
PZ-61DR-E transmission cable connection																																																																		
M-NET transmission cable connection																																																																		
External signal cable connection																																																																		
Cover screw (black)																																																																		

Step	Details	Check item	
6	<p>Function setting with PZ-61DR-E</p> <p>When PZ-61DR-E is connected, according to the function status record data prepared in Step 2, set the function settings with PZ-61DR-E. If PZ-61DR-E is not connected, skip this step and proceed to Step 7. To perform function settings with PZ-61DR-E, see the Lossnay technical manual or remote controller manual.</p> <p>The selection method for "M-NET address" on the function setting screen differs between when the address setting switch on the Lossnay circuit board is set (the address is other than "00") and when it is not set (the address is "00"). Check the address setting of the replaced circuit board.</p> <p><When the address switch setting is other than "00"> For all function settings, always select the address of the Lossnay unit which the circuit boards were replaced. Even when there are multiple Lossnay units in the group, do not select "All".</p> <p><When the address switch is "00"> Always select "All".</p> <p>Note:</p> <ul style="list-style-type: none"> When changing the settings of the function selection switches and address setting switches on the circuit board after the functions were set with PZ-61DR-E, reset the function settings according to "(7) Initialization" (page 45). After resetting the function settings, perform the function settings again in the order of Step 5 ① and Step 6. If you change the M-NET address after the functions were set with PZ-61DR-E, the settings with PZ-61DR-E will be reset. In this case, set the functions again with PZ-61DR-E. 	Address setting	
		Function setting	
7	<p>Restarting the system</p> <p>Turn the power back on to the Lossnay unit which the circuit boards have been replaced, or when using M-NET, turn the power back on to the power supply unit connected to the Lossnay unit. In trial operation, make sure that the Lossnay unit with replaced circuit boards operates properly, and finish replacement work.</p>	Trial operation	

(7) Initialization

Set to initialize the remote controller PZ-61DR-E function setting.
All function settings which are changed by users are cancelled.

DIP-SW		Setting check	PZ-61DR-E		Setting check	Initialization
SW No.	Setting		Function No.	Setting Data		
N/A	-	-	100	0		N/A
	-	-		1		Available

(8) Setting status record

① Basic information

Date: _____

Installation location: _____

Model name: LGH- (15 · 25 · 35 · 50 · 65 · 80 · 100 · 150 · 200) RVX-E

Serial number on the nameplate (eight-digit): _____

Address setting: _____

Lot number marked on the circuit board: _____

Microcomputer software version marked on the circuit board: _____

Lossnay remote controller: (Used · Not used) Model name: _____

Interlock setting: (Set · Not set) Model name: _____

System controller: (Used · Not used) Model name: _____

The number of Lossnay units in a group: _____

Address number (The smallest number in the group): _____

② Function selection switches

Enter the setting status of the function selection switches on the circuit board.

SW2	ON	OFF
1	<input type="checkbox"/>	<input type="checkbox"/>
2	<input type="checkbox"/>	<input type="checkbox"/>
3	<input type="checkbox"/>	<input type="checkbox"/>
4	<input type="checkbox"/>	<input type="checkbox"/>
5	<input type="checkbox"/>	<input type="checkbox"/>
6	<input type="checkbox"/>	<input type="checkbox"/>
7	<input type="checkbox"/>	<input type="checkbox"/>
8	<input type="checkbox"/>	<input type="checkbox"/>
9	<input type="checkbox"/>	<input type="checkbox"/>
10	<input type="checkbox"/>	<input type="checkbox"/>

SW5	ON	OFF
1	<input type="checkbox"/>	<input type="checkbox"/>
2	<input type="checkbox"/>	<input type="checkbox"/>
3	<input type="checkbox"/>	<input type="checkbox"/>
4	<input type="checkbox"/>	<input type="checkbox"/>
5	<input type="checkbox"/>	<input type="checkbox"/>
6	<input type="checkbox"/>	<input type="checkbox"/>
7	<input type="checkbox"/>	<input type="checkbox"/>
8	<input type="checkbox"/>	<input type="checkbox"/>
9	<input type="checkbox"/>	<input type="checkbox"/>
10	<input type="checkbox"/>	<input type="checkbox"/>

SW6	ON	OFF
1	<input type="checkbox"/>	<input type="checkbox"/>
2	<input type="checkbox"/>	<input type="checkbox"/>
3	<input type="checkbox"/>	<input type="checkbox"/>
4	<input type="checkbox"/>	<input type="checkbox"/>

Note: SW6 setting differs according to the model.

Model	SW6-1	SW6-2	SW6-3	SW6-4
LGH-15RVX-E	ON	OFF	OFF	OFF
LGH-25RVX-E	OFF	ON	OFF	OFF
LGH-35RVX-E	ON	ON	OFF	OFF
LGH-50RVX-E	OFF	OFF	ON	OFF
LGH-65RVX-E	ON	OFF	ON	OFF
LGH-80RVX-E	OFF	ON	ON	OFF
LGH-100RVX-E	ON	ON	ON	OFF
LGH-150RVX-E	OFF	OFF	OFF	ON
LGH-200RVX-E	ON	OFF	OFF	ON

■ : Factory setting

③ Function settings

Enter the setting data of the functions set with PZ-61DR-E.

Function No.	Setting Data
1	(0)
2	(0)
5	(0)
6	(0)
7	(0)
8	(0)
9	(0)
13	(0)
14	(0)

Function No.	Setting Data
15	(0)
28	(0)
30	(0)
31	(5)
32	(2)
34	(0)
36	(0)
37	(0)
38	(0)

Function No.	Setting Data
39	(7)
40	(0)
41	(7)
42	(7)
51	(0)
52	(0)
53	(6)
54	(1)
55	(0)

Function No.	Setting Data
56	(0)
57	(0)
58	(0)
59	(0)
60	(0)
61	(0)
62	(0)
63	(0)
100	(0)

() : Factory setting

④ External input

Enter the usage of the external input/output on the control circuit board.

Terminal or connector on the circuit board	Function Name	Used	Not used	Connected device
TM2 ①②③	External control input	<input type="checkbox"/>	<input type="checkbox"/>	
CN32	Remote/local switching	<input type="checkbox"/>	<input type="checkbox"/>	
CN17 ①②	Fan speed 4 input	<input type="checkbox"/>	<input type="checkbox"/>	
CN17 ①③	Fan speed 3 input	<input type="checkbox"/>	<input type="checkbox"/>	
CN17 ①④	Fan speed 2 input	<input type="checkbox"/>	<input type="checkbox"/>	
CN17 ①⑤	Fan speed 1 input	<input type="checkbox"/>	<input type="checkbox"/>	
CN26 ①②	Bypass mode input	<input type="checkbox"/>	<input type="checkbox"/>	
CN26 ④⑤	Fan speed switching input (0 to 10 V DC)	<input type="checkbox"/>	<input type="checkbox"/>	
TM3 ⑦⑩	Bypass monitor or Pre-heater output	<input type="checkbox"/>	<input type="checkbox"/>	
TM3 ⑧⑩	Malfunction monitor output	<input type="checkbox"/>	<input type="checkbox"/>	
TM3 ⑨⑩	Operation monitor output	<input type="checkbox"/>	<input type="checkbox"/>	

LGH-15RVX-E

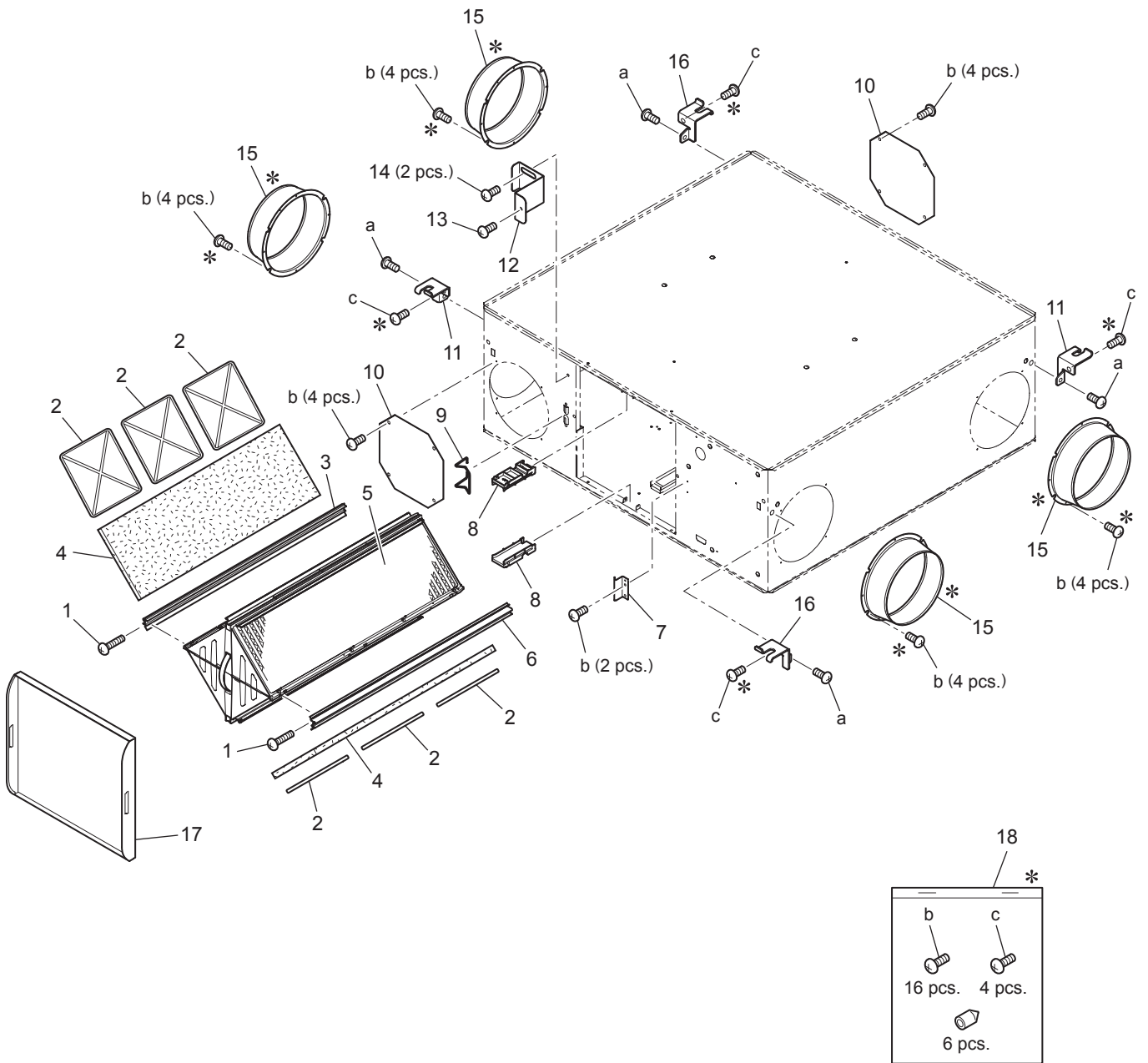

<Standard screws>

Symbol	Screw name
a	PT screw 6x12
b	PTT screw 4x8
c	PT screw 5x10

* shows accessory parts.

LGH-15RVX-E

No.	Name of part	Parts No.	Q'ty pcs/unit	Critical for safety	Remarks
1	Spl screw M4	R50 541 045	2		
2	Filter stopper	R50 520 710	6		
3	Core guide L	R50 614 382	1		
4	Filter	Y50 169 717	2	⚠	
5	Lossnay core	Y50 169 710	1	⚠	With filter stoppers
6	Core guide R	R50 614 383	1		
7	Fix piece	R50 614 712	1		
8	Lead support	R50 614 706	2		
9	Hinge	R50 466 344	1		
10	Cover	R50 541 705	2		
11	Hanger L	R50 614 381	2		
12	Fix piece	Y50 169 707	1		
13	Spl screw 4×8	K81 469 018	4		
14	Spl screw 4×8	Y50 169 045	2		
15	Flange	R50 384 617	4		With a cushion
16	Hanger R	R50 614 380	2		
17	Maint. cover	R50 614 708	1		With cushions
18	Parts in bag	Y50 169 049	1		

Air exhaust fan assembly

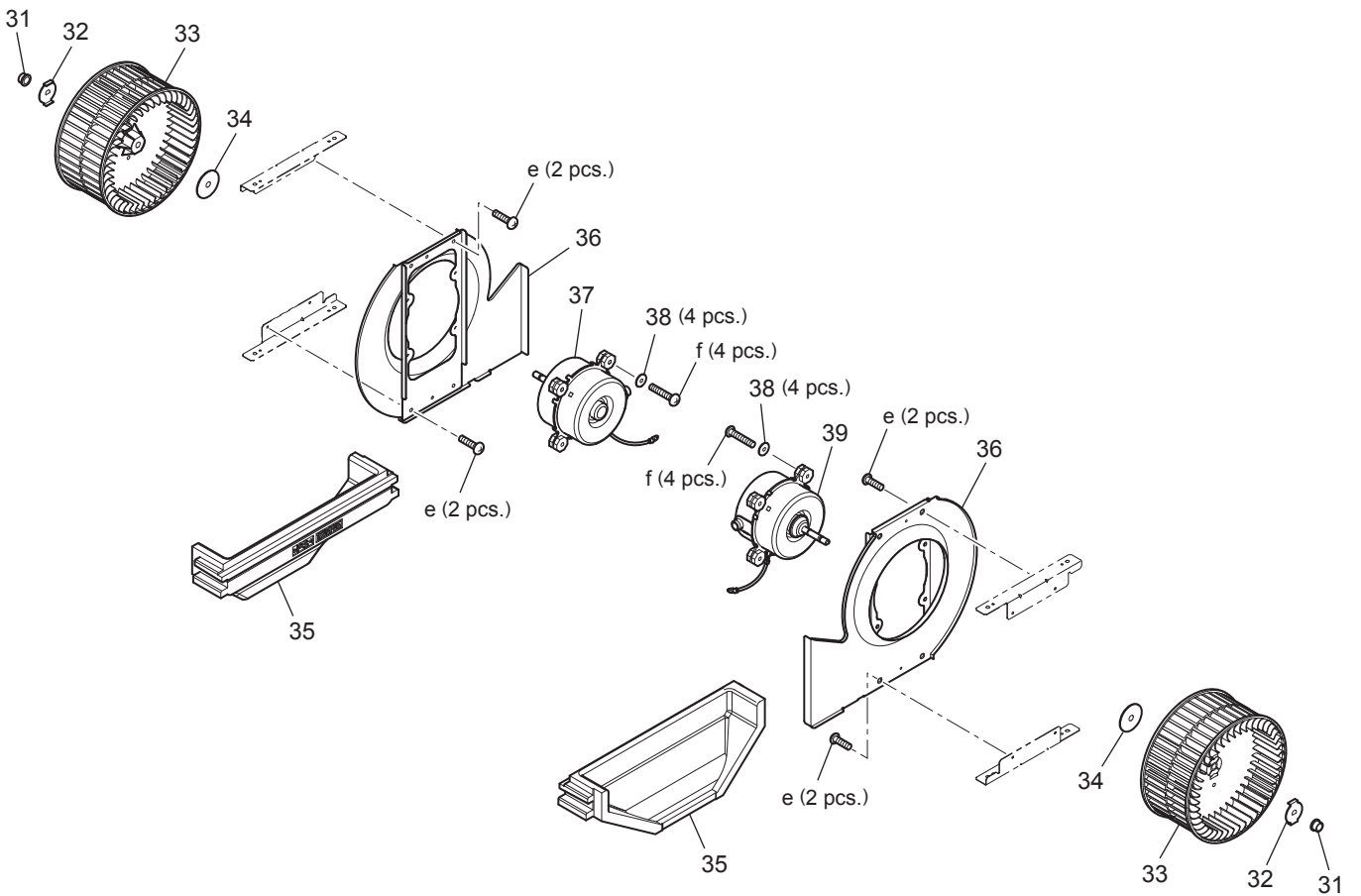

Air supply fan assembly

<Standard screws>

Symbol	Screw name
e	PTT screw 4x10
f	PTT screw 4x25

LGH-15RVX-E

No.	Name of part	Parts No.	Q'ty pcs/unit	Critical for safety	Remarks
31	Special nut (8)	R50 331 067	2		Left-handed φ 180 φ 8.1
32	Tab washer	M34 398 077	2		
33	Centrifugal fan	R50 614 480	2	⚠	
34	Special washer	R50 028 465	2		
35	Separator	R50 541 488	2		
36	Motor fix plate	Y50 169 712	2		
37	Motor	Y50 169 454	1	⚠	
38	Spl washer 4.2	R50 089 080	8		
39	Motor	Y50 169 453	1	⚠	

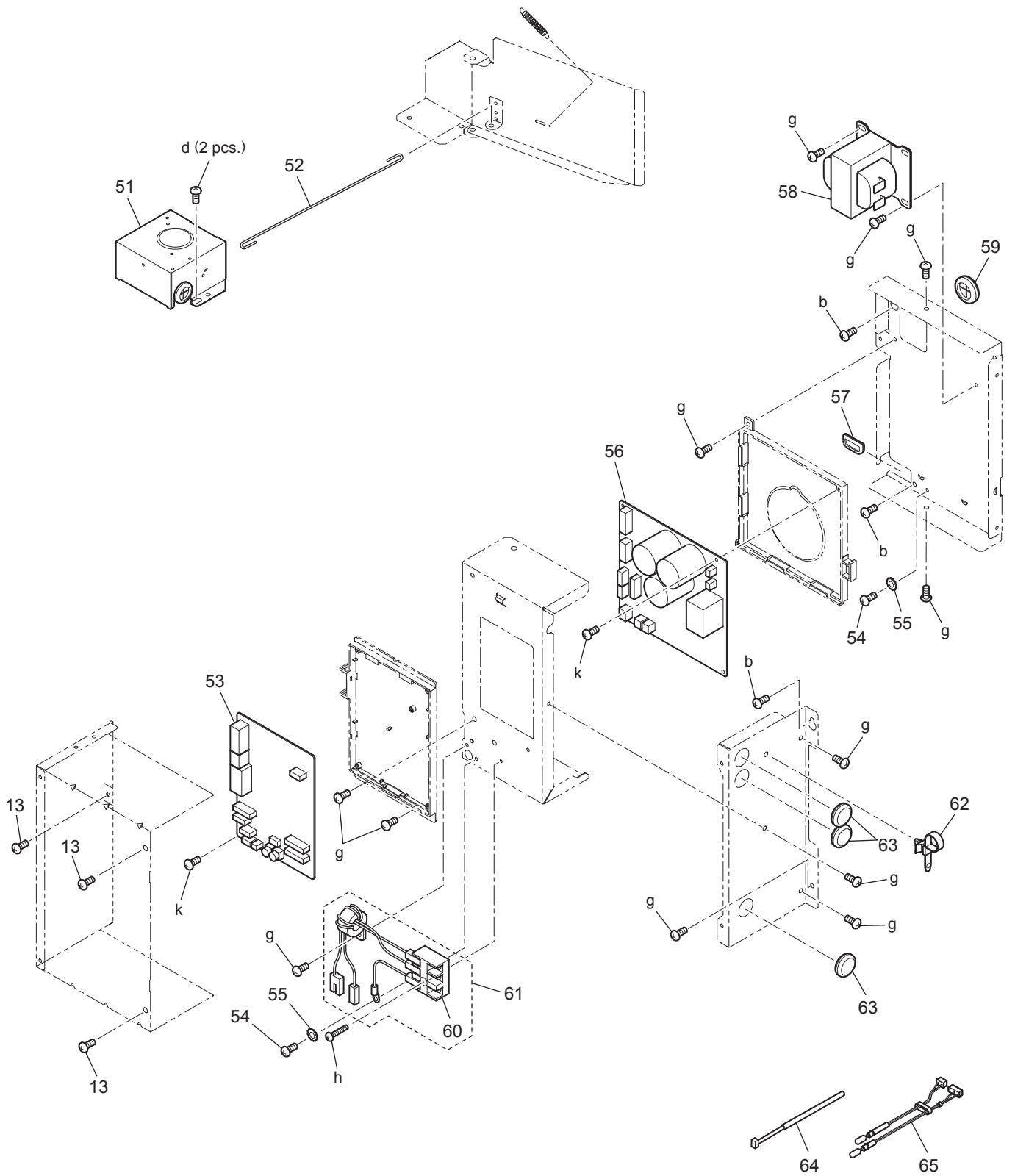

<Standard screws>

Symbol	Screw name
b	PTT screw 4x8
g	PT screw 4x8
h	PPT screw 4x20
k	PPT screw 3x8

LGH-15RVX-E

No.	Name of part	Parts No.	Q'ty pcs/unit	Critical for safety	Remarks
51	GM assy	Y50 169 260	1	▲	AC220·240V
52	Rod	R50 541 150	1		
53	Circuit board	Y50 169 173	1	▲	LG-X05DC-E·C
54	PT screw 4×8 BS	H00 011 008	2		
55	Lock washer (4)	H00 013 076	2		
56	Circuit board	Y50 169 172	1	▲	LG-X05DC-E·P
57	Bush	R50 541 225	1		
58	Reactor	Y50 169 179	1	▲	
59	Bush	R50 476 225	1		
60	Terminal block	Y45 631 242	1	▲	3P
61	Lead wire	Y50 169 213	1	▲	With the terminal block
62	Cord band	Y55 001 223	1		
63	Bush	K83 223 225	3		
64	Lead wire	Y50 047 231	1	▲	100mm
65	Thermistor	Y50 169 167	1	▲	-30°C to 100°C

LGH-25RVX-E

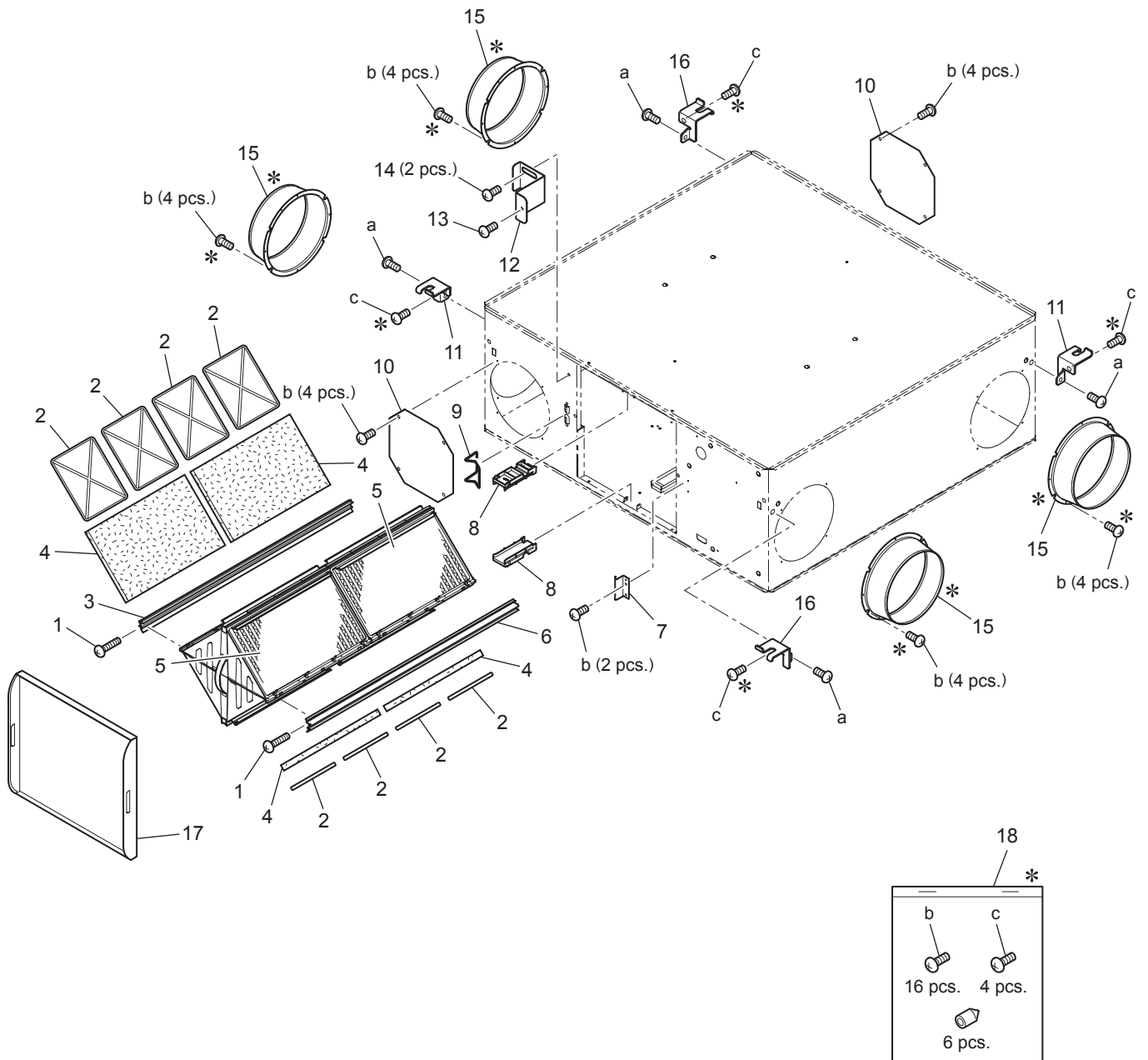

<Standard screws>

Symbol	Screw name
a	PT screw 6x12
b	PTT screw 4x8
c	PT screw 5x10

* shows accessory parts.

LGH-25RVX-E

No.	Name of part	Parts No.	Q'ty pcs/unit	Critical for safety	Remarks
1	Spl screw M4	R50 541 045	2		
2	Filter stopper	X50 039 710	8		
3	Core guide L	R50 614 384	1		
4	Filter	X50 039 717	4	⚠	
5	Lossnay core	Y50 169 711	2	⚠	With the filter stoppers
6	Core guide R	R50 614 385	1		
7	Fix piece	R50 614 712	1		
8	Lead support	R50 614 706	2		
9	Hinge	R50 466 344	1		
10	Cover	R50 541 717	2		
11	Hanger L	R50 614 381	2		
12	Fix piece	Y50 169 707	1		
13	Spl screw 4×8	K81 469 018	4		
14	Spl screw 4×8	Y50 169 045	2		
15	Flange	Y50 075 609	4		With a cushion
16	Hanger R	R50 614 380	2		
17	Maint. cover	R50 614 708	1		With cushions
18	Parts in bag	Y50 169 049	1		

Air exhaust fan assembly

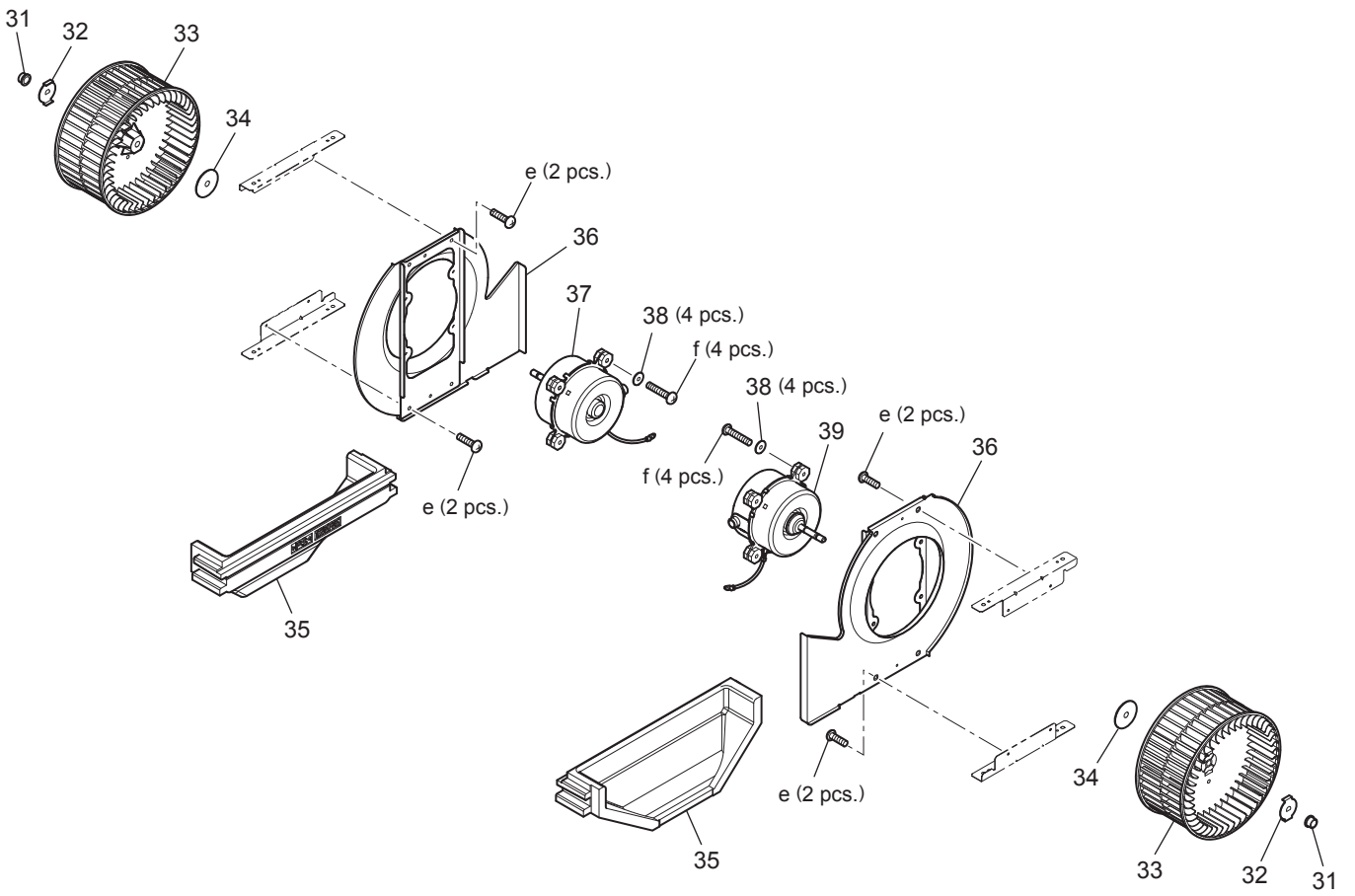

Air supply fan assembly

<Standard screws>

Symbol	Screw name
e	PTT screw 4x10
f	PTT screw 4x25

LGH-25RVX-E

No.	Name of part	Parts No.	Q'ty pcs/unit	Critical for safety	Remarks
31	Special nut (8)	R50 331 067	2		Left-handed φ 180 φ 8.1
32	Tab washer	M34 398 077	2		
33	Centrifugal fan	R50 614 480	2	⚠	
34	Special washer	R50 028 465	2		
35	Separator	R50 541 488	2		
36	Motor fix plate	Y50 169 712	2		
37	Motor	Y50 169 454	1	⚠	
38	Spl washer 4.2	R50 089 080	8		
39	Motor	Y50 169 453	1	⚠	

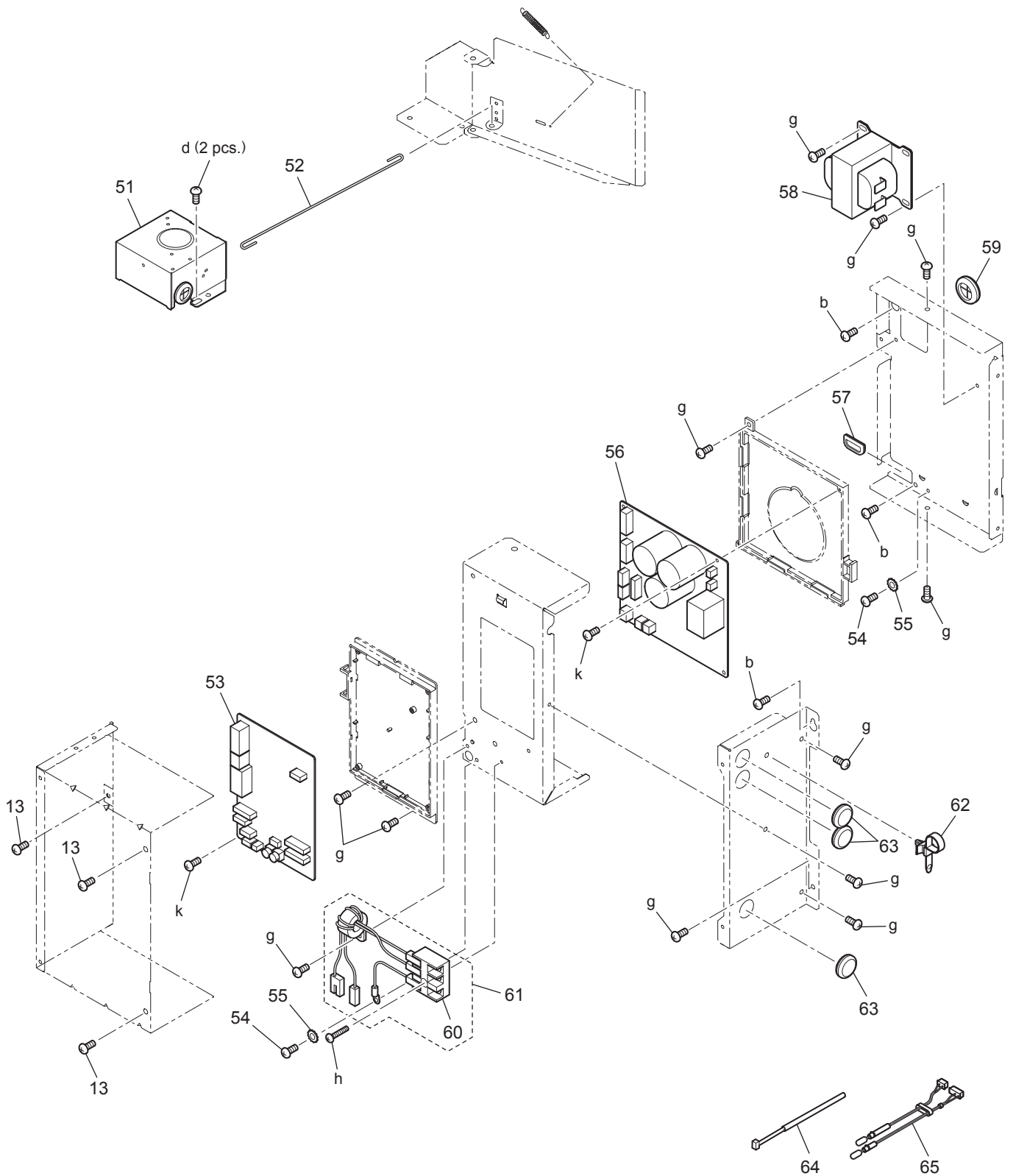

<Standard screws>

Symbol	Screw name
b	PTT screw 4x8
g	PT screw 4x8
h	PPT screw 4x20
k	PPT screw 3x8

LGH-25RVX-E

No.	Name of part	Parts No.	Q'ty pcs/unit	Critical for safety	Remarks
51	GM assy	Y50 169 260	1	▲	AC220·240V
52	Rod	R50 541 151	1		
53	Circuit board	Y50 169 173	1	▲	LG-X05DC-E·C
54	PT screw 4×8 BS	H00 011 008	2		
55	Lock washer (4)	H00 013 076	2		
56	Circuit board	Y50 169 172	1	▲	LG-X05DC-E·P
57	Bush	R50 541 225	1		
58	Reactor	Y50 169 179	1	▲	
59	Bush	R50 476 225	1		
60	Terminal block	Y45 631 242	1	▲	3P
61	Lead wire	Y50 169 213	1	▲	With the terminal block
62	Cord band	Y55 001 223	1		
63	Bush	K83 223 225	3		
64	Lead wire	Y50 047 231	1	▲	100mm
65	Thermistor	Y50 169 168	1	▲	-30°C to 100°C

LGH-35RVX-E

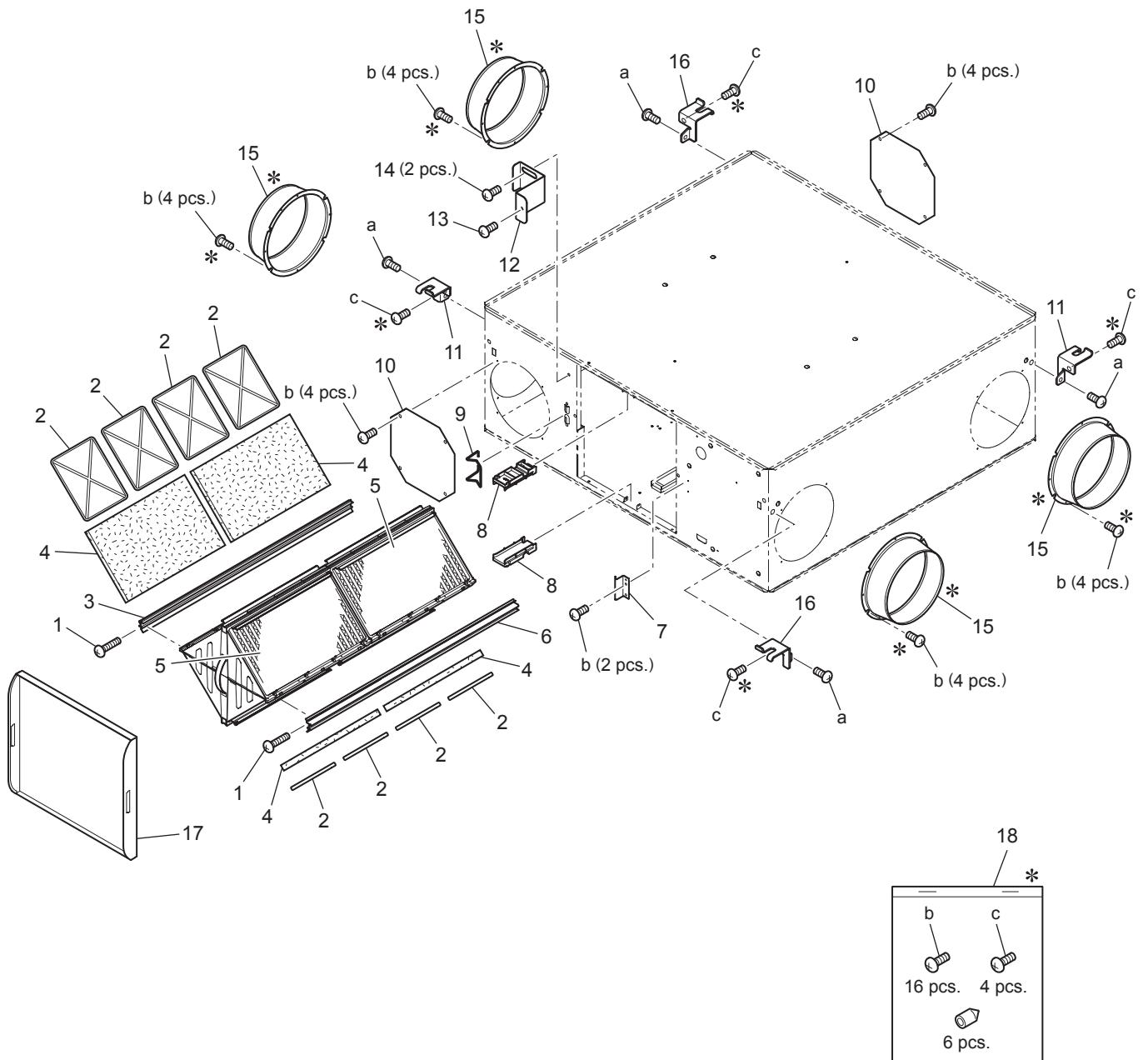

<Standard screws>

Symbol	Screw name
a	PT screw 6x12
b	PTT screw 4x8
c	PT screw 5x10

* shows accessory parts.

LGH-35RVX-E

No.	Name of part	Parts No.	Q'ty pcs/unit	Critical for safety	Remarks
1	Spl screw M4	R50 541 045	2		
2	Filter stopper	R50 521 710	8		
3	Core guide L	R50 615 381	1		
4	Filter	Y50 116 717	4	⚠	
5	Lossnay core	Y50 170 710	2	⚠	With the filter stoppers
6	Core guide R	R50 615 382	1		
7	Fix piece	R50 614 712	1		
8	Lead support	R50 614 706	2		
9	Hinge	R50 466 344	1		
10	Cover	R50 541 717	2		
11	Hanger L	R50 614 381	2		
12	Fix piece	Y50 169 707	1		
13	Spl screw 4×8	K81 469 018	4		
14	Spl screw 4×8	Y50 169 045	2		
15	Flange	Y50 075 609	4		With a cushion
16	Hanger R	R50 614 380	2		
17	Maint. cover	R50 615 708	1		With cushions
18	Parts in bag	Y50 169 049	1		

Air exhaust fan assembly

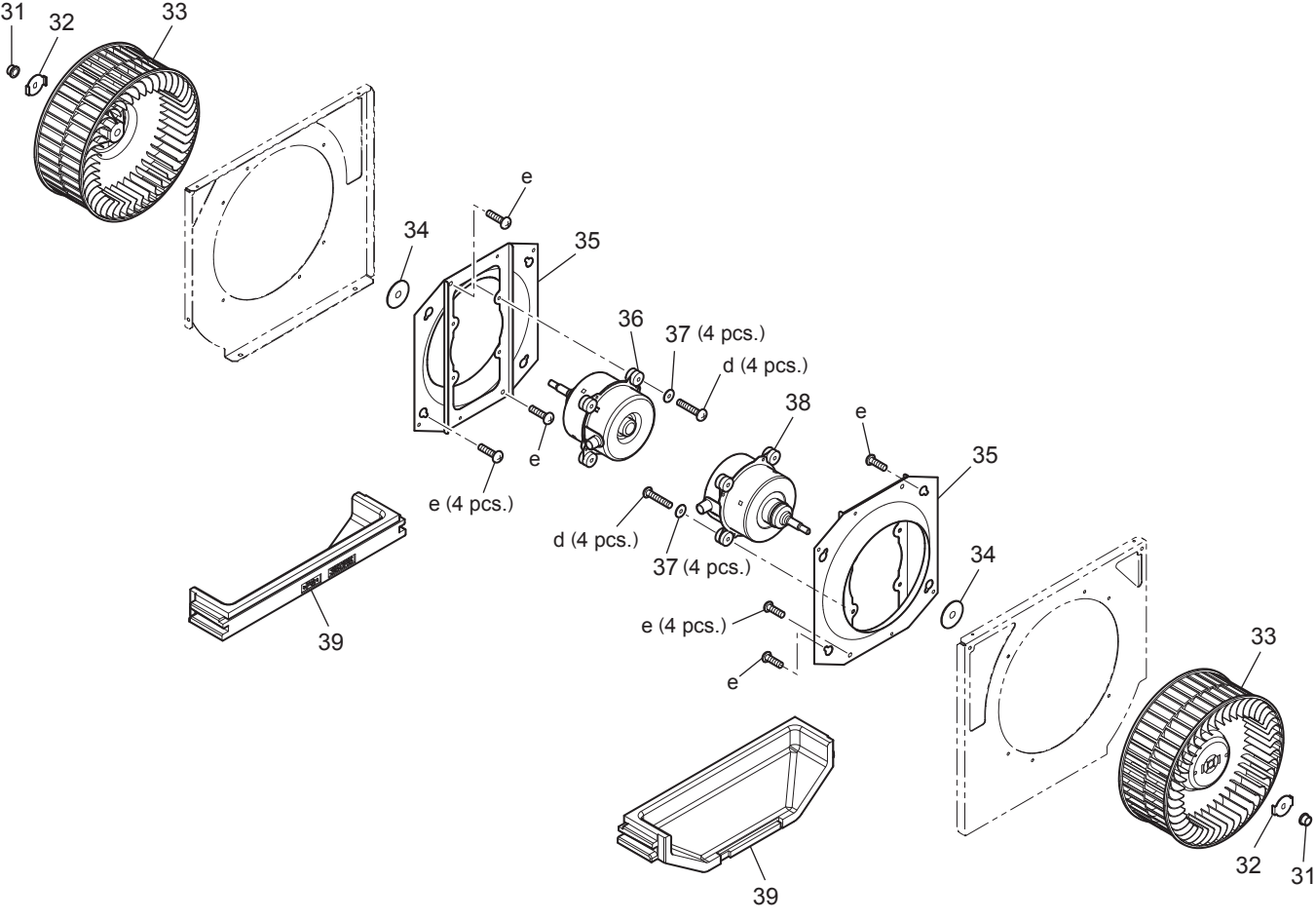

Air supply fan assembly

<Standard screws>

Symbol	Screw name
d	PTT screw 4x25
e	PTT screw 5x10

LGH-35RVX-E

No.	Name of part	Parts No.	Q'ty pcs/unit	Critical for safety	Remarks
31	Special nut (8)	R50 331 067	2		Left-handed φ 220
32	Tab washer	M34 398 077	2		
33	Centrifugal fan	R50 615 480	2	⚠	
34	Spl washer (10)	M34 706 465	2		
35	Motor fix plate	Y50 170 712	2		
36	Motor	Y50 170 454	1	⚠	
37	Spl washer 4.2	R50 089 080	8		
38	Motor	Y50 170 453	1	⚠	
39	Separator	R50 615 486	2		

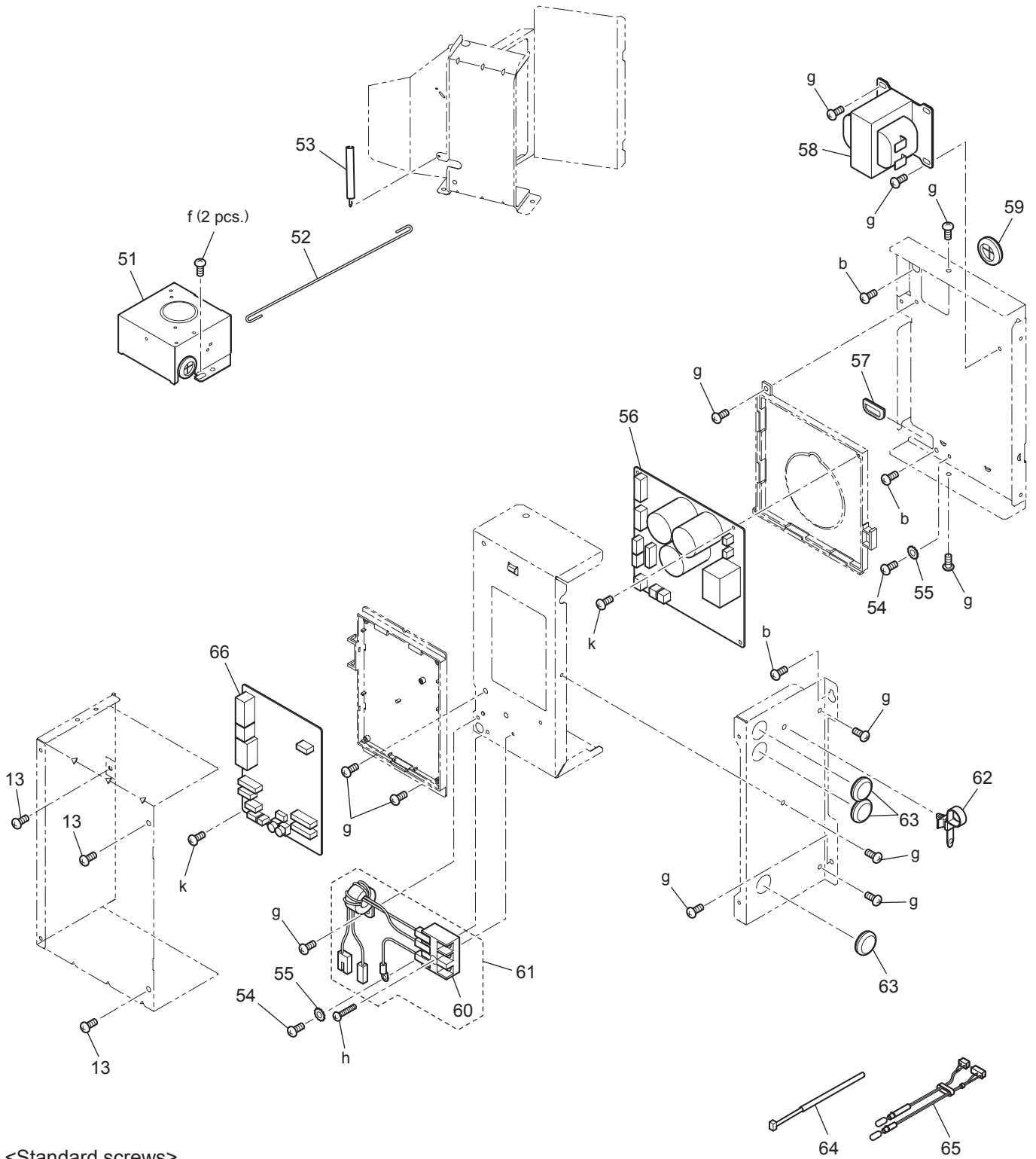

<Standard screws>

Symbol	Screw name
b	PTT screw 4x8
f	PTT screw 4x6
g	PT screw 4x8
h	PPT screw 4x20
k	PPT screw 3x8

LGH-35RVX-E

No.	Name of part	Parts No.	Q'ty pcs/unit	Critical for safety	Remarks
51	GM assy	Y50 170 260	1	▲	AC220·240V
52	Rod	Y50 170 150	1		
53	Pull spring	R50 573 157	1		
54	PT screw 4×8 BS	H00 011 008	2		
55	Lock washer (4)	H00 013 076	2		
56	Circuit board	Y50 169 172	1	▲	LG-X05DC-E·P 3P
57	Bush	R50 541 225	1		
58	Reactor	Y50 169 179	1	▲	
59	Bush	R50 476 225	1		
60	Terminal block	Y45 631 242	1	▲	
61	Lead wire	Y50 169 213	1	▲	
62	Cord band	Y55 001 223	1		With the terminal block 100mm -30°C to 100°C
63	Bush	K83 223 225	3		
64	Lead wire	Y50 047 231	1	▲	
65	Thermistor	Y50 170 167	1	▲	
66	Circuit board	Y50 169 173	1	▲	

LGH-50RVX-E

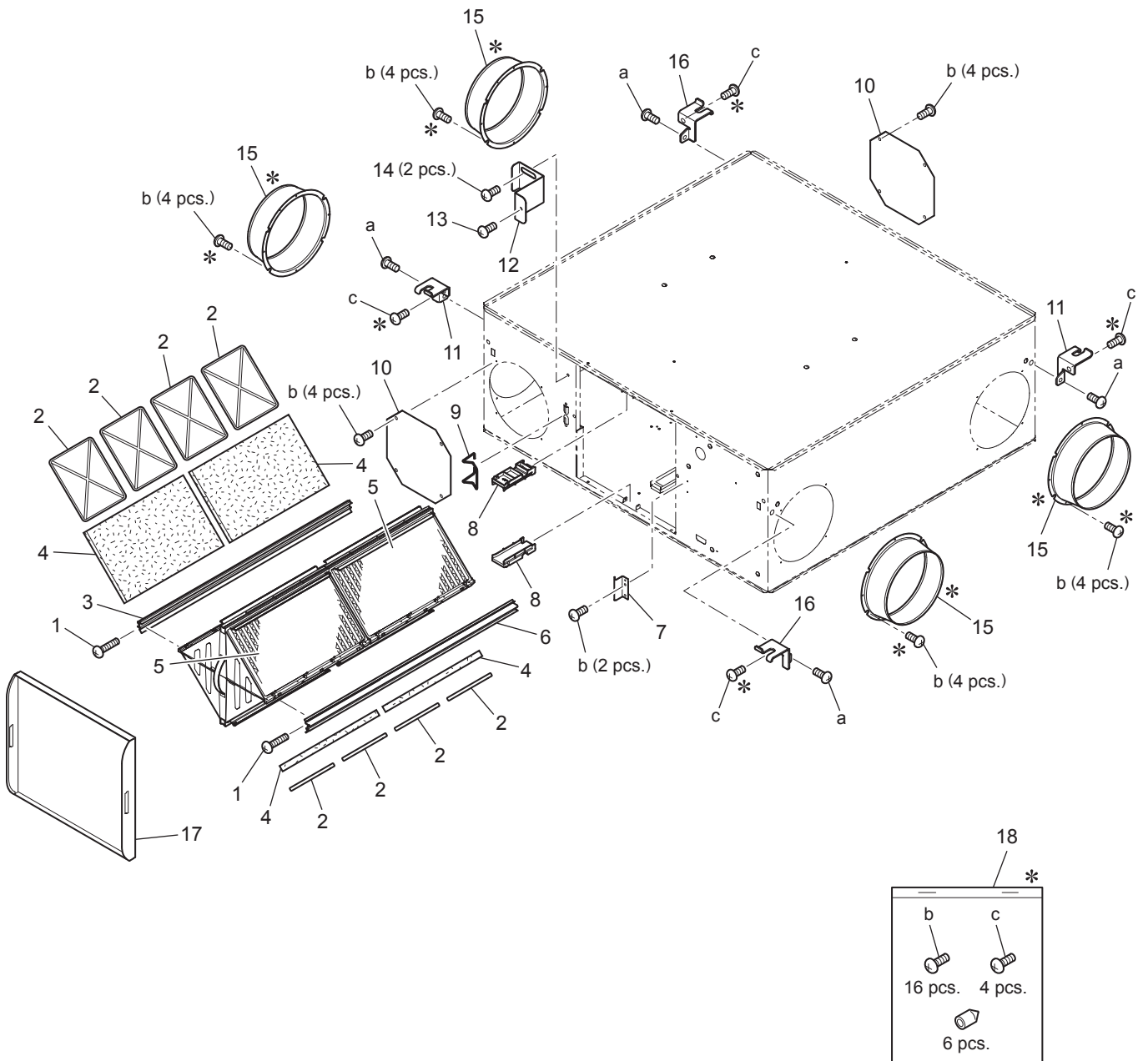

<Standard screws>

Symbol	Screw name
a	PT screw 6x12
b	PTT screw 4x8
c	PT screw 5x10

* shows accessory parts.

LGH-50RVX-E

No.	Name of part	Parts No.	Q'ty pcs/unit	Critical for safety	Remarks
1	Spl screw M4	R50 541 045	2		
2	Filter stopper	R50 521 710	8		
3	Core guide L	R50 615 383	1		
4	Filter	R50 521 717	4	⚠	
5	Lossnay core	Y50 170 711	2	⚠	With the filter stoppers
6	Core guide R	R50 615 384	1		
7	Fix piece	R50 614 712	1		
8	Lead support	R50 614 706	2		
9	Hinge	R50 466 344	1		
10	Cover	R50 542 706	2		
11	Hanger L	R50 614 381	2		
12	Fix piece	Y50 169 707	1		
13	Spl screw 4×8	K81 469 018	4		
14	Spl screw 4×8	Y50 169 045	2		
15	Flange	R50 429 609	4		With a cushion
16	Hanger R	R50 614 380	2		
17	Maint. cover	R50 615 708	1		With cushions
18	Parts in bag	Y50 169 049	1		

Air exhaust fan assembly

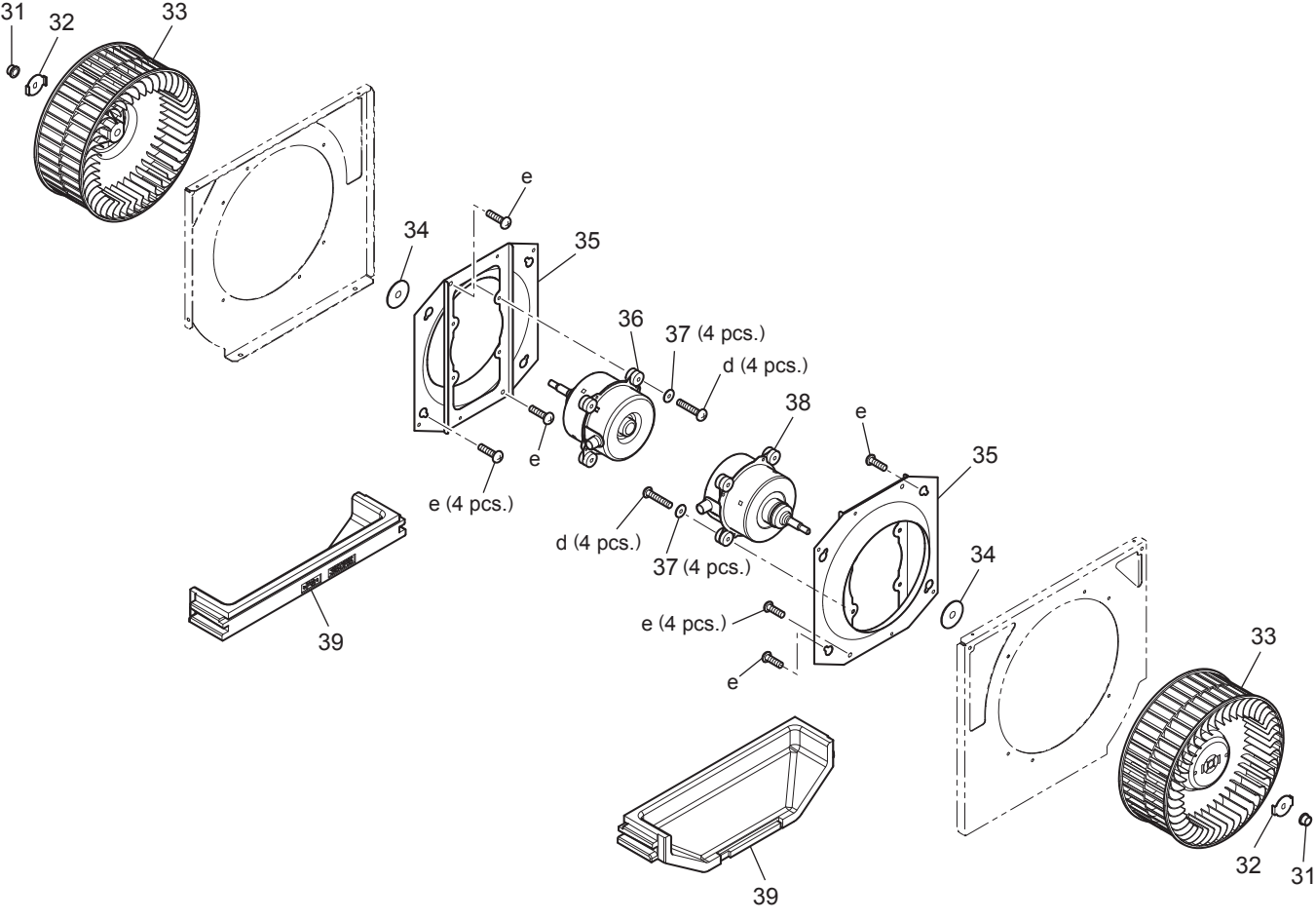

Air supply fan assembly

<Standard screws>

Symbol	Screw name
d	PTT screw 4x25
e	PTT screw 5x10

LGH-50RVX-E

No.	Name of part	Parts No.	Q'ty pcs/unit	Critical for safety	Remarks
31	Special nut (8)	R50 331 067	2		Left-handed φ 220
32	Tab washer	M34 398 077	2		
33	Centrifugal fan	R50 615 480	2	⚠	
34	Special washer	M34 706 465	2		
35	Motor fix plate	Y50 170 712	2		
36	Motor	Y50 170 454	1	⚠	
37	Spl washer 4.2	R50 089 080	8		
38	Motor	Y50 170 453	1	⚠	
39	Separator	R50 615 486	2		

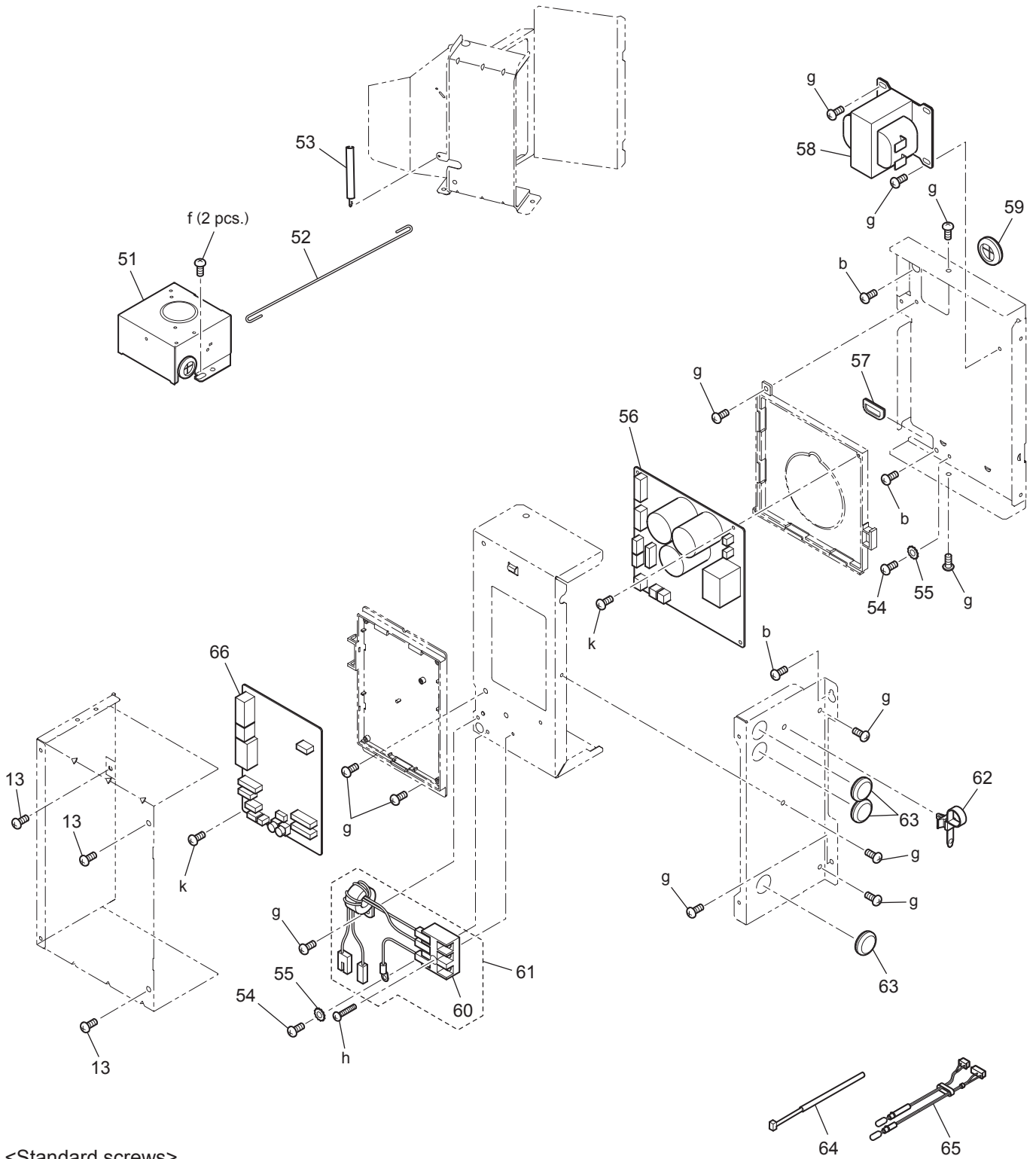

<Standard screws>

Symbol	Screw name
b	PTT screw 4x8
f	PTT screw 4x6
g	PT screw 4x8
h	PPT screw 4x20
k	PPT screw 3x8

LGH-50RVX-E

No.	Name of part	Parts No.	Q'ty pcs/unit	Critical for safety	Remarks
51	GM assy	Y50 170 261	1	▲	AC220·240V
52	Rod	Y50 170 150	1		
53	Pull spring	R50 573 157	1		
54	PT screw 4×8 BS	H00 011 008	2		
55	Lock washer (4)	H00 013 076	2		
56	Circuit board	Y50 169 172	1	▲	LG-X05DC-E·P 3P
57	Bush	R50 541 225	1		
58	Reactor	Y50 169 179	1	▲	
59	Bush	R50 476 225	1		
60	Terminal block	Y45 631 242	1	▲	
61	Lead wire	Y50 169 213	1	▲	
62	Cord band	Y55 001 223	1		With the terminal block
63	Bush	K83 223 225	3		
64	Lead wire	Y50 047 231	1	▲	
65	Thermistor	Y50 170 168	1	▲	100mm -30°C to 100°C
66	Circuit board	Y50 169 173	1	▲	LG-X05DC-E·C

LGH-65RVX-E

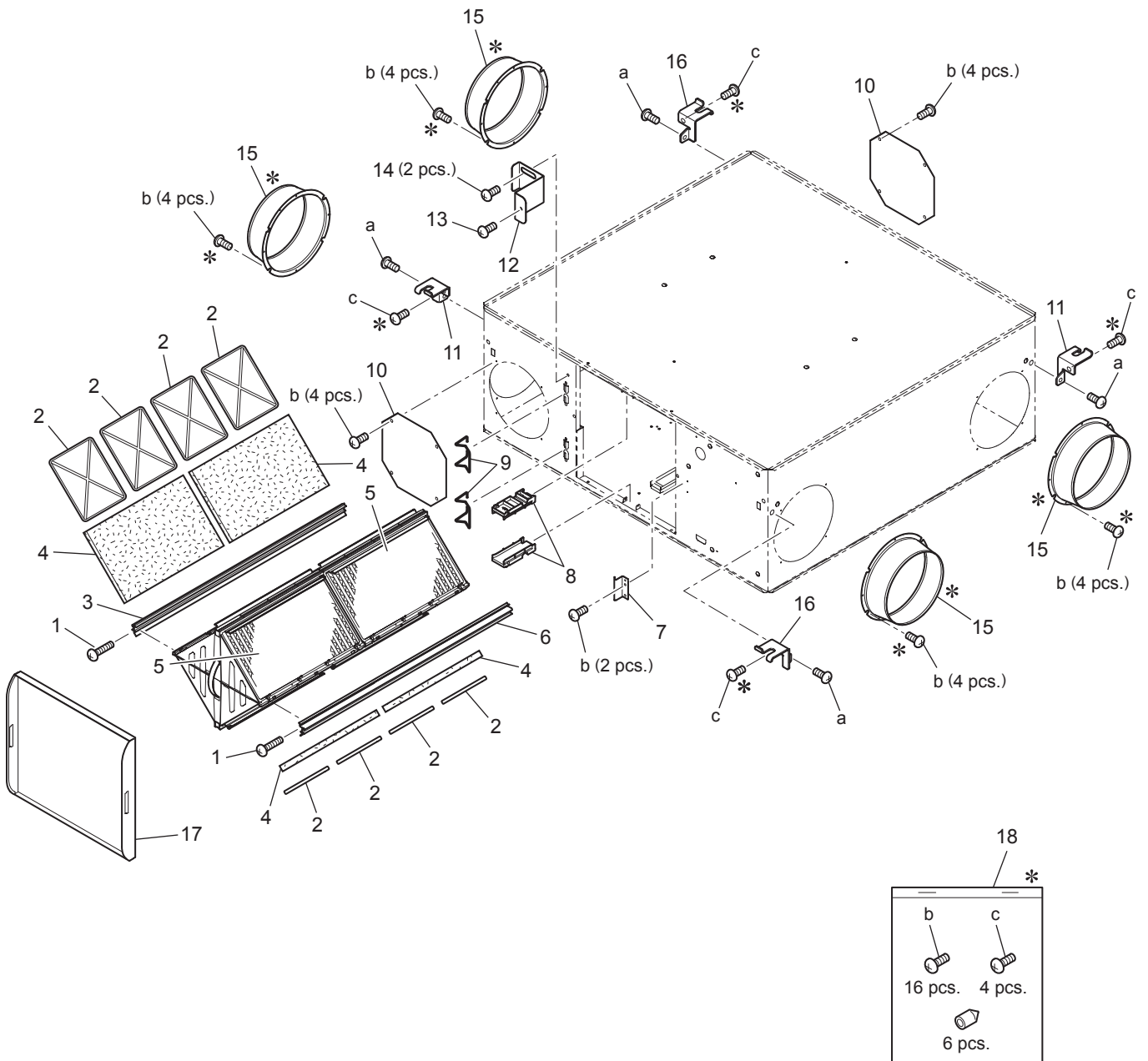

<Standard screws>

Symbol	Screw name
a	PT screw 6x12
b	PTT screw 4x8
c	PT screw 5x10

* shows accessory parts.

LGH-65RVX-E

No.	Name of part	Parts No.	Q'ty pcs/unit	Critical for safety	Remarks
1	Spl screw M4	R50 541 045	2		
2	Filter stopper	R50 524 710	8		
3	Core guide L	R50 616 381	1		
4	Filter	R50 524 717	4	⚠	
5	Lossnay core	Y50 171 710	2	⚠	With the filter stoppers
6	Core guide R	R50 616 382	1		
7	Fix piece	R50 614 712	1		
8	Lead support	R50 614 706	2		
9	Hinge	R50 466 344	2		
10	Cover	R50 542 706	2		
11	Hanger L	R50 614 381	2		
12	Fix piece	Y50 169 707	1		
13	Spl screw 4×8	K81 469 018	4		
14	Spl screw 4×8	Y50 169 045	2		
15	Flange	R50 429 609	4		With a cushion
16	Hanger R	R50 614 380	2		
17	Maint. cover	R50 616 708	1		With cushions
18	Parts in bag	Y50 169 049	1		

Air exhaust fan assembly

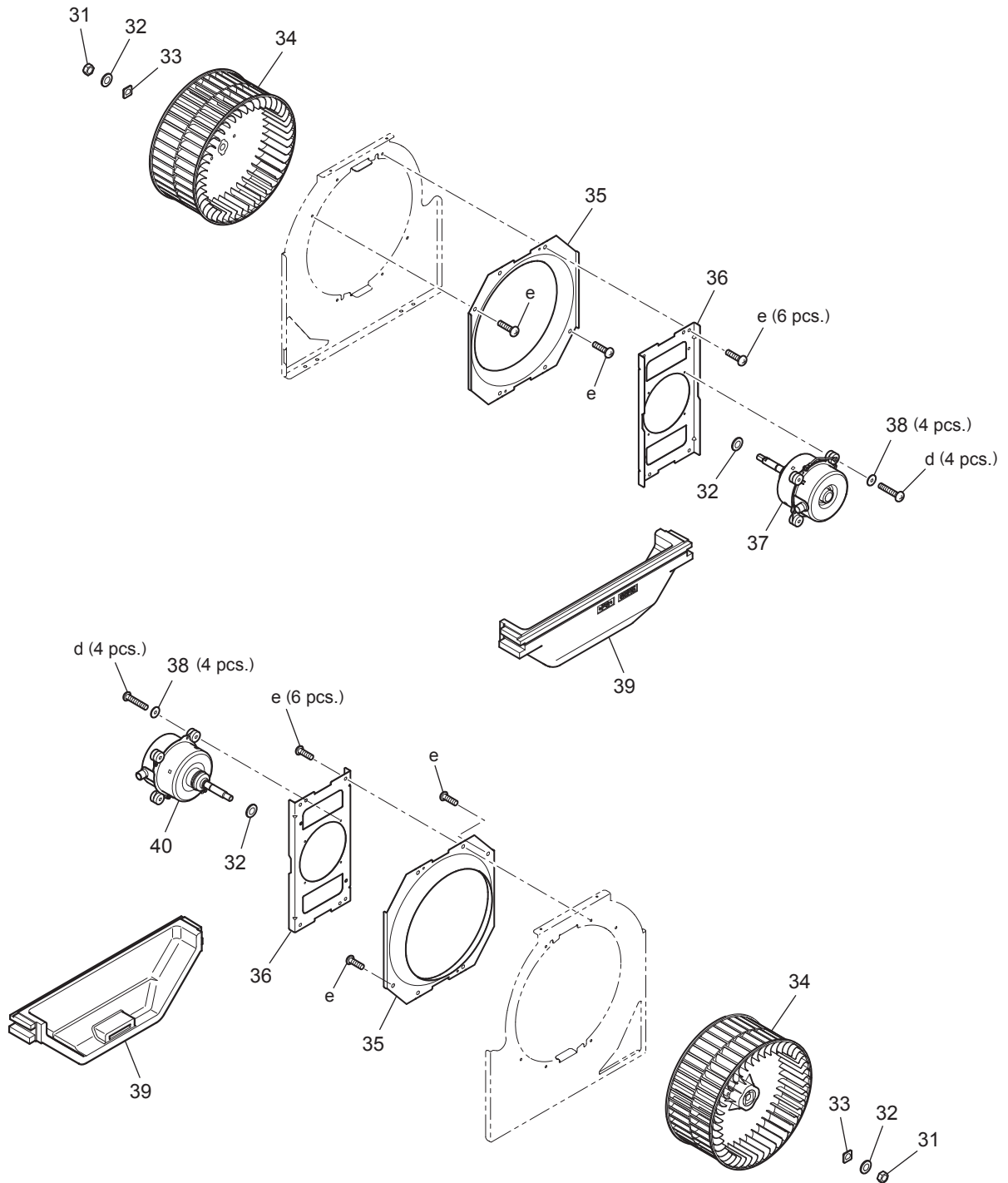

<Standard screws>

Symbol	Screw name
d	PTT screw 4x25
e	PTT screw 5x10

Air supply fan assembly

LGH-65RVX-E

No.	Name of part	Parts No.	Q'ty pcs/unit	Critical for safety	Remarks
31	Special nut (10)	M34 545 067	2		Left-handed φ 245
32	Washer (12)	K83 466 113	4		
33	Tab washer	Y50 171 707	2		
34	Centrifugal fan	Y50 171 480	2	⚠	
35	Inlet ring	R50 543 708	2		
36	Motor fix plate	Y50 171 712	2		
37	Motor	Y50 171 454	1	⚠	
38	Spl washer 4.2	R50 089 080	8		
39	Separator	R50 543 488	2		
40	Motor	Y50 171 453	1	⚠	

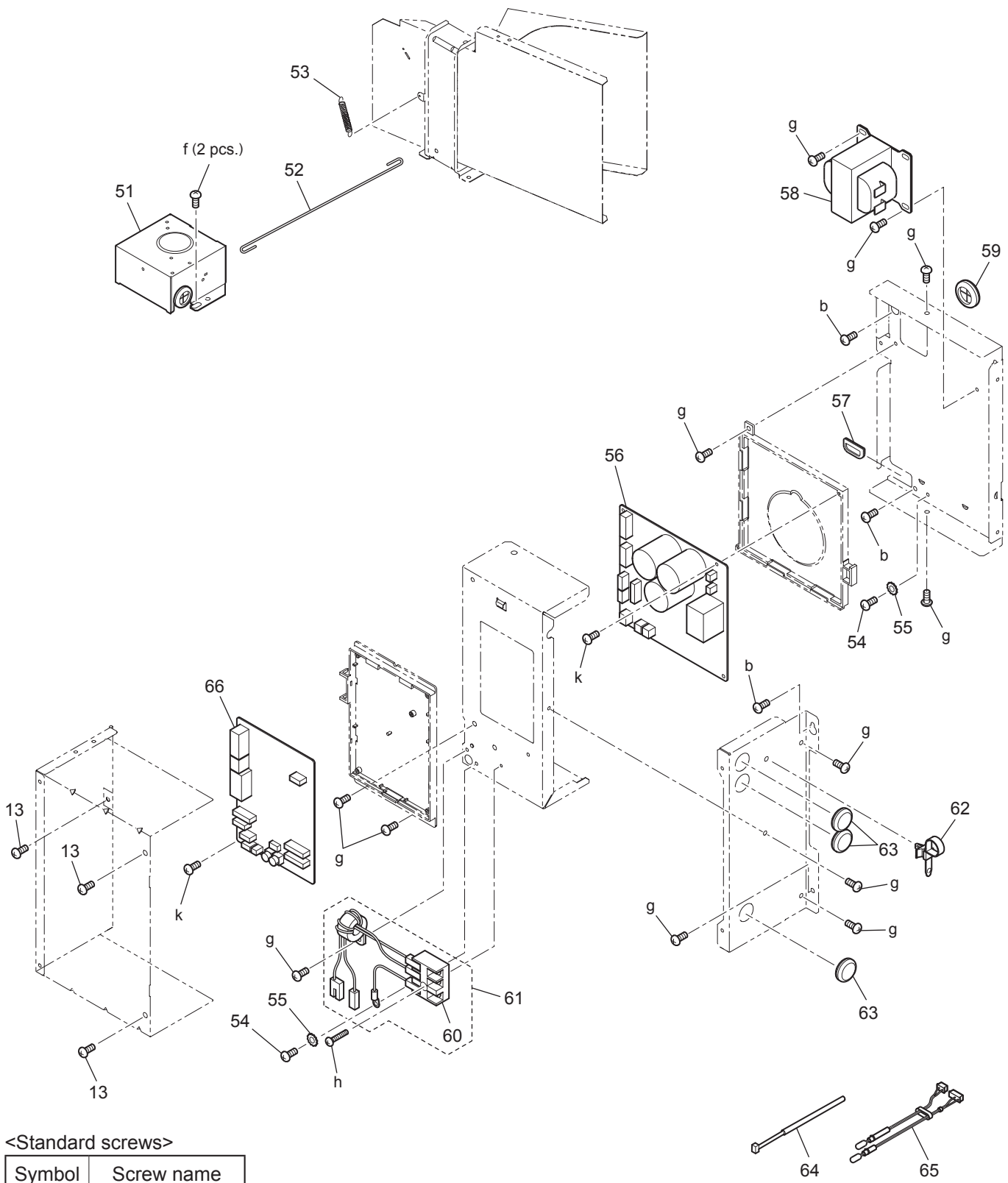

<Standard screws>

Symbol	Screw name
b	PTT screw 4x8
f	PTT screw 4x6
g	PT screw 4x8
h	PPT screw 4x20
k	PPT screw 3x8

LGH-65RVX-E

No.	Name of part	Parts No.	Q'ty pcs/unit	Critical for safety	Remarks
51	GM assy	Y50 171 260	1	▲	AC220·240V
52	Rod	R50 217 150	1		
53	Pull spring	R50 637 156	1		
54	PT screw 4×8 BS	H00 011 008	2		
55	Lock washer (4)	H00 013 076	2		
56	Circuit board	Y50 169 172	1	▲	LG-X05DC-E·P 3P
57	Bush	R50 541 225	1		
58	Reactor	Y50 169 179	1	▲	
59	Bush	R50 476 225	1		
60	Terminal block	Y45 631 242	1	▲	
61	Lead wire	Y50 169 213	1	▲	
62	Cord band	Y55 001 223	1		With the terminal block
63	Bush	K83 223 225	3		
64	Lead wire	Y50 047 231	1	▲	
65	Thermistor	Y50 170 168	1	▲	100mm -30°C to 100°C
66	Circuit board	Y50 169 173	1	▲	LG-X05DC-E·C

LGH-80RVX-E

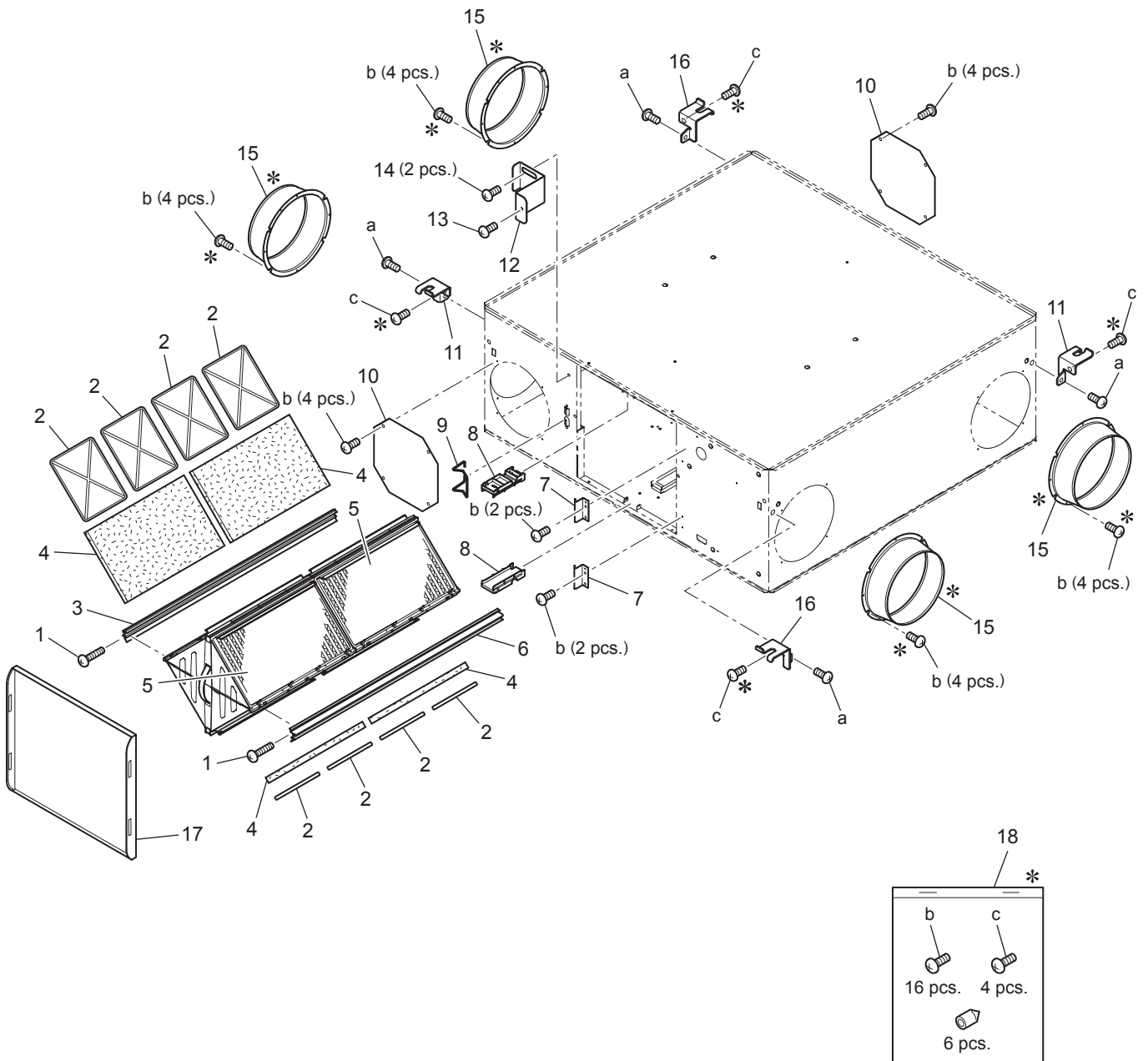

<Standard screws>

Symbol	Screw name
a	PT screw 6x12
b	PTT screw 4x8
c	PT screw 5x10

* shows accessory parts.

LGH-80RVX-E

No.	Name of part	Parts No.	Q'ty pcs/unit	Critical for safety	Remarks
1	Spl screw M4	R50 541 045	2		
2	Filter stopper	R50 522 710	8		
3	Core guide L	R50 616 383	1		
4	Filter	R50 529 717	4	⚠	
5	Lossnay core	Y50 172 710	2	⚠	With the filter stoppers
6	Core guide R	R50 616 384	1		
7	Fix piece	R50 614 712	2		
8	Lead support	R50 616 704	2		
9	Hinge	R50 466 344	1		
10	Cover	R50 543 704	2		
11	Hanger L	R50 614 381	2		
12	Fix piece	Y50 169 707	1		
13	Spl screw 4×8	K81 469 018	4		
14	Spl screw 4×8	Y50 169 045	2		
15	Flange	Y50 021 609	4		With a cushion
16	Hanger R	R50 614 380	2		
17	Maint. cover	R50 616 709	1		With cushions
18	Parts in bag	Y50 169 049	1		

Air exhaust fan assembly

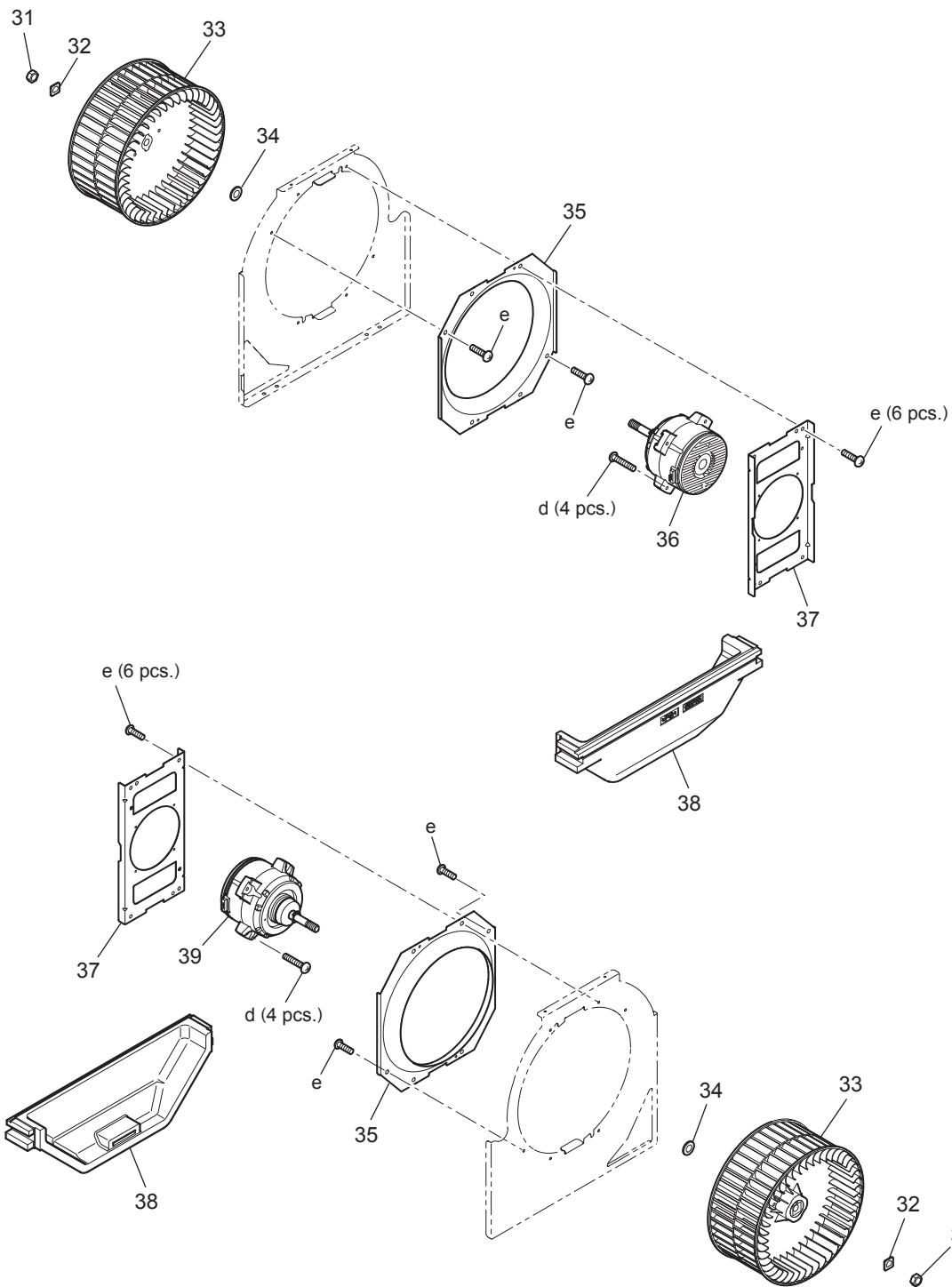

<Standard screws>

Symbol	Screw name
d	PTT screw 4x25
e	PTT screw 5x10

Air supply fan assembly

LGH-80RVX-E

No.	Name of part	Parts No.	Q'ty pcs/unit	Critical for safety	Remarks
31	Spl nut (12)	R50 218 067	2		Left-handed φ 245
32	Tab washer	Y50 171 707	2		
33	Centrifugal fan	Y50 171 480	2	⚠	
34	Washer (12)	K83 466 113	2		
35	Inlet ring	R50 543 708	2		
36	Motor	Y50 172 454	1	⚠	
37	Motor fix plate	Y50 171 712	2		
38	Separator	R50 616 486	2		
39	Motor	Y50 172 453	1	⚠	

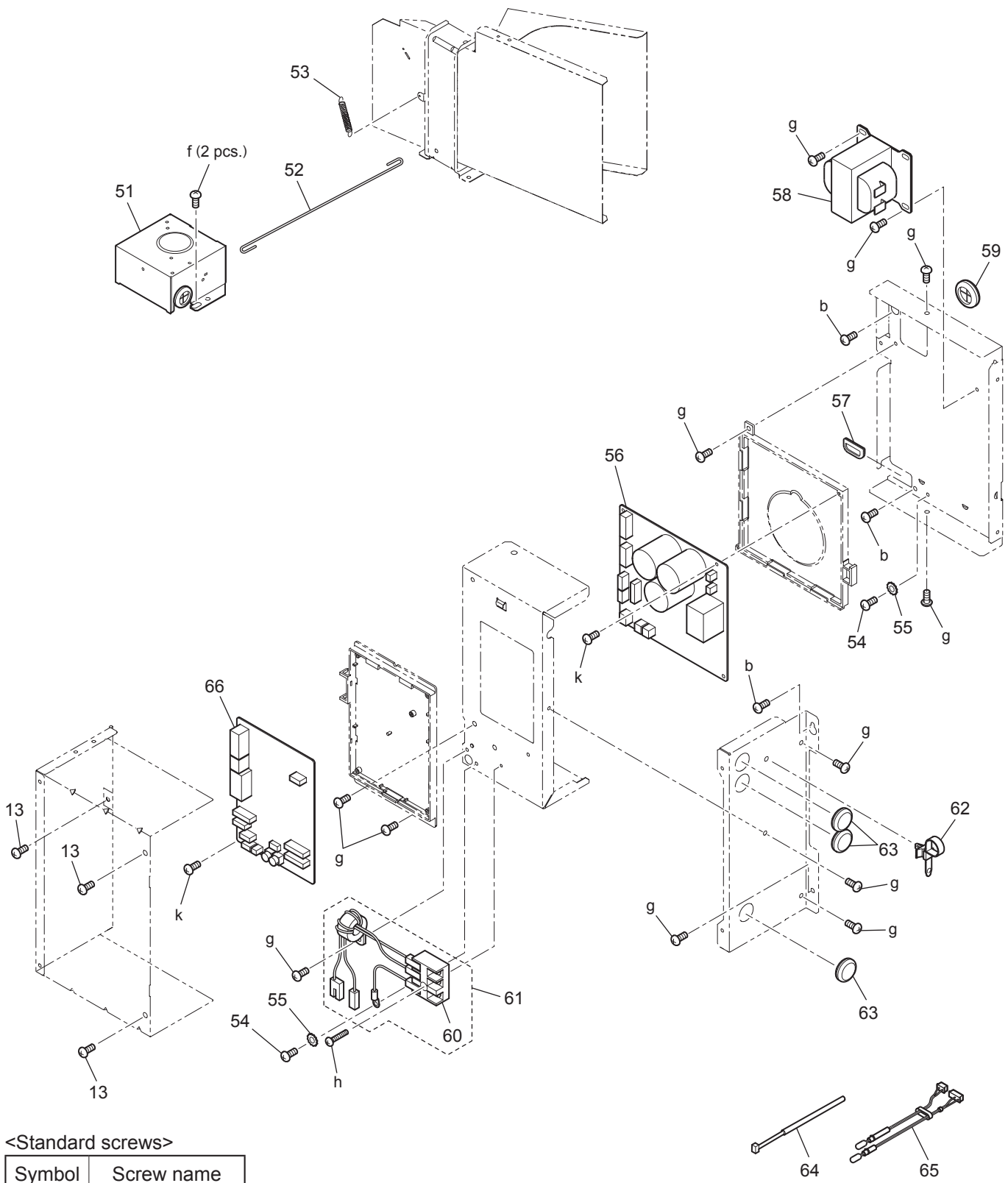

<Standard screws>

Symbol	Screw name
b	PTT screw 4x8
f	PTT screw 4x6
g	PT screw 4x8
h	PPT screw 4x20
k	PPT screw 3x8

LGH-80RVX-E

No.	Name of part	Parts No.	Q'ty pcs/unit	Critical for safety	Remarks
51	GM assy	Y50 172 260	1	▲	AC220·240V
52	Rod	R50 543 150	1		
53	Pull spring	R50 637 156	1		
54	PT screw 4×8 BS	H00 011 008	2		
55	Lock washer (4)	H00 013 076	2		
56	Circuit board	Y50 169 172	1	▲	LG-X05DC-E·P 3P
57	Bush	R50 541 225	1		
58	Reactor	Y50 172 179	1	▲	
59	Bush	R50 476 225	1		
60	Terminal block	Y45 631 242	1	▲	
61	Lead wire	Y50 169 213	1	▲	
62	Cord band	Y55 001 223	1		With the terminal block
63	Bush	K83 223 225	3		
64	Lead wire	Y50 047 231	1	▲	
65	Thermistor	Y50 170 168	1	▲	100mm -30°C to 100°C
66	Circuit board	Y50 169 173	1	▲	LG-X05DC-E·C

LGH-100RVX-E

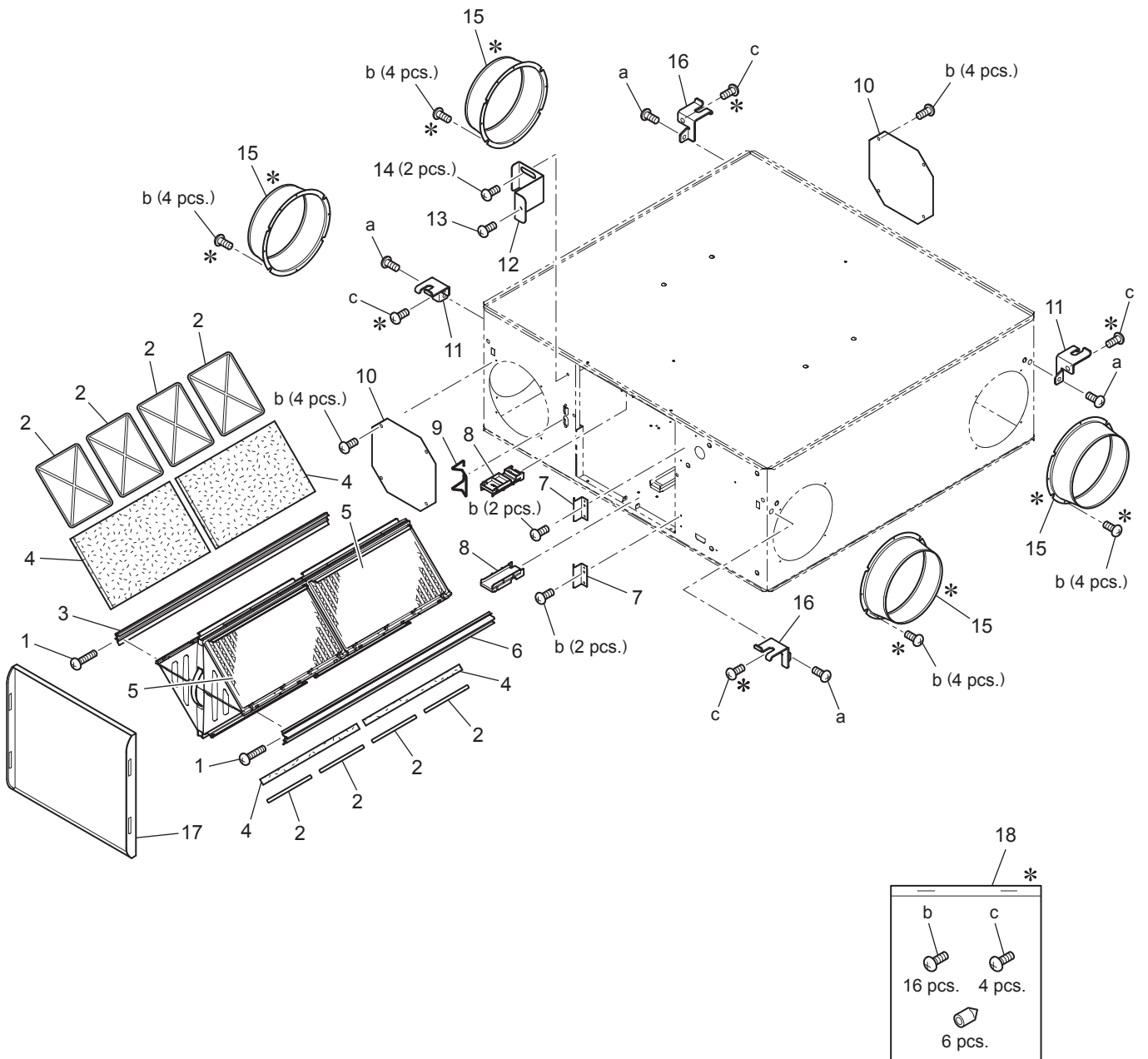

<Standard screws>

Symbol	Screw name
a	PT screw 6x12
b	PTT screw 4x8
c	PT screw 5x10

* shows accessory parts.

LGH-100RVX-E

No.	Name of part	Parts No.	Q'ty pcs/unit	Critical for safety	Remarks
1	Spl screw M4	R50 541 045	2		
2	Filter stopper	R50 522 710	8		
3	Core guide L	R50 617 381	1		
4	Filter	R50 522 717	4	⚠	
5	Lossnay core	Y50 172 711	2	⚠	With the filter stoppers
6	Core guide R	R50 617 382	1		
7	Fix piece	R50 614 712	2		
8	Lead support	R50 616 704	2		
9	Hinge	R50 466 344	1		
10	Cover	R50 543 704	2		
11	Hanger L	R50 614 381	2		
12	Fix piece	Y50 169 707	1		
13	Spl screw 4×8	K81 469 018	4		
14	Spl screw 4×8	Y50 169 045	2		
15	Flange	Y50 021 609	4		With a cushion
16	Hanger R	R50 614 380	2		
17	Maint. cover	R50 616 709	1		With cushions
18	Parts in bag	Y50 169 049	1		

Air exhaust fan assembly

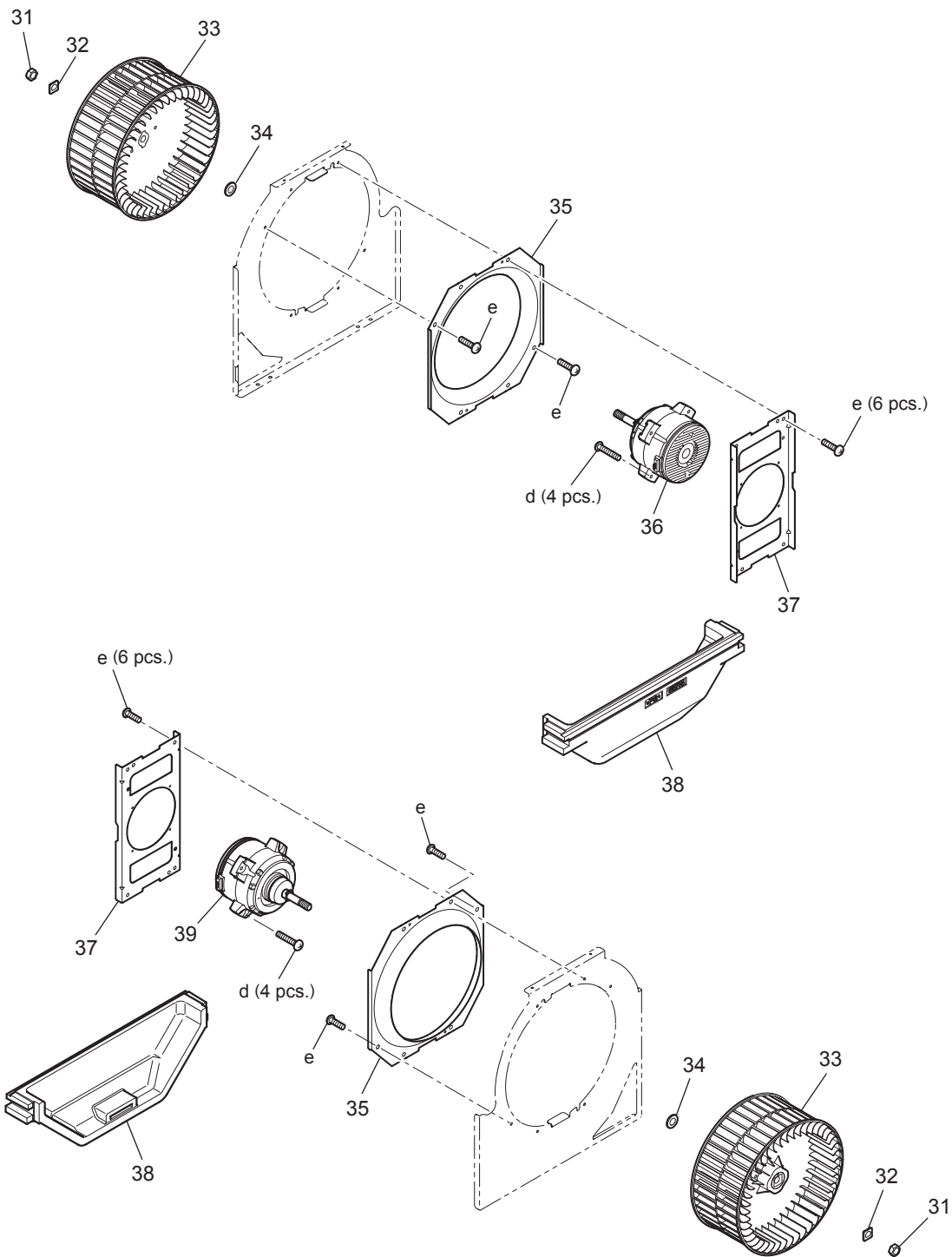

<Standard screws>

Symbol	Screw name
d	PTT screw 4x25
e	PTT screw 5x10

Air supply fan assembly

LGH-100RVX-E

No.	Name of part	Parts No.	Q'ty pcs/unit	Critical for safety	Remarks
31	Spl nut (12)	R50 218 067	2		Left-handed φ 245
32	Tab washer	Y50 171 707	2		
33	Centrifugal fan	Y50 171 480	2	⚠	
34	Washer (12)	K83 466 113	2		
35	Inlet ring	R50 543 708	2		
36	Motor	Y50 172 454	1	⚠	
37	Motor fix plate	Y50 171 712	2		
38	Separator	R50 616 486	2		
39	Motor	Y50 172 453	1	⚠	

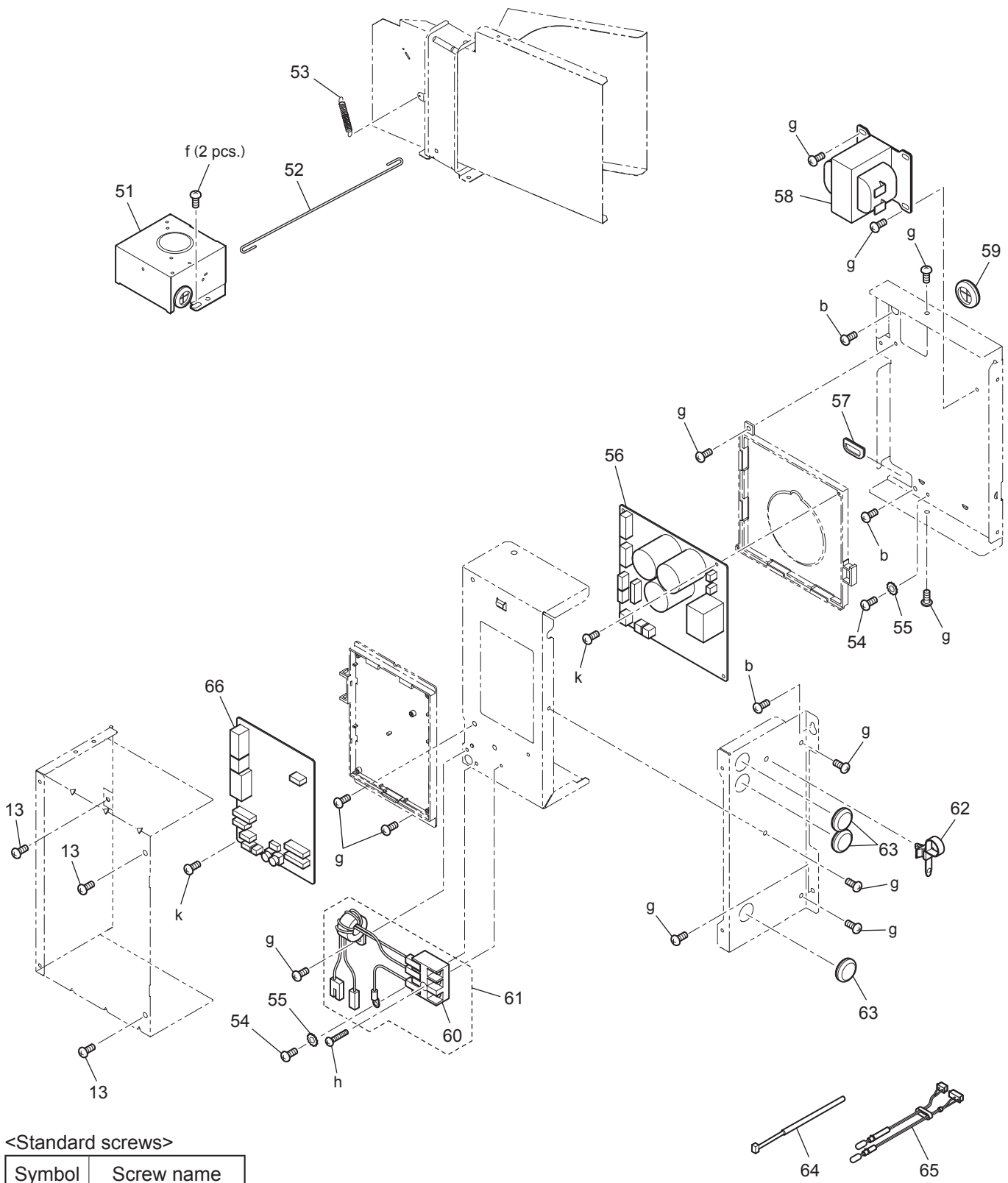

<Standard screws>

Symbol	Screw name
b	PTT screw 4x8
f	PTT screw 4x6
g	PT screw 4x8
h	PPT screw 4x20
k	PPT screw 3x8

LGH-100RVX-E

No.	Name of part	Parts No.	Q'ty pcs/unit	Critical for safety	Remarks
51	GM assy	Y50 172 261	1	▲	AC220·240V
52	Rod	R50 543 150	1		
53	Pull spring	R50 637 156	1		
54	PT screw 4×8 BS	H00 011 008	2		
55	Lock washer (4)	H00 013 076	2		
56	Circuit board	Y50 169 172	1	▲	LG-X05DC-E·P 3P
57	Bush	R50 541 225	1		
58	Reactor	Y50 172 180	1	▲	
59	Bush	R50 476 225	1		
60	Terminal block	Y45 631 242	1	▲	
61	Lead wire	Y50 169 213	1	▲	
62	Cord band	Y55 001 223	1		With the terminal block
63	Bush	K83 223 225	3		
64	Lead wire	Y50 047 231	1	▲	
65	Thermistor	Y50 172 167	1	▲	100mm -30°C to 100°C
66	Circuit board	Y50 169 173	1	▲	LG-X05DC-E·C

LGH-150RVX-E

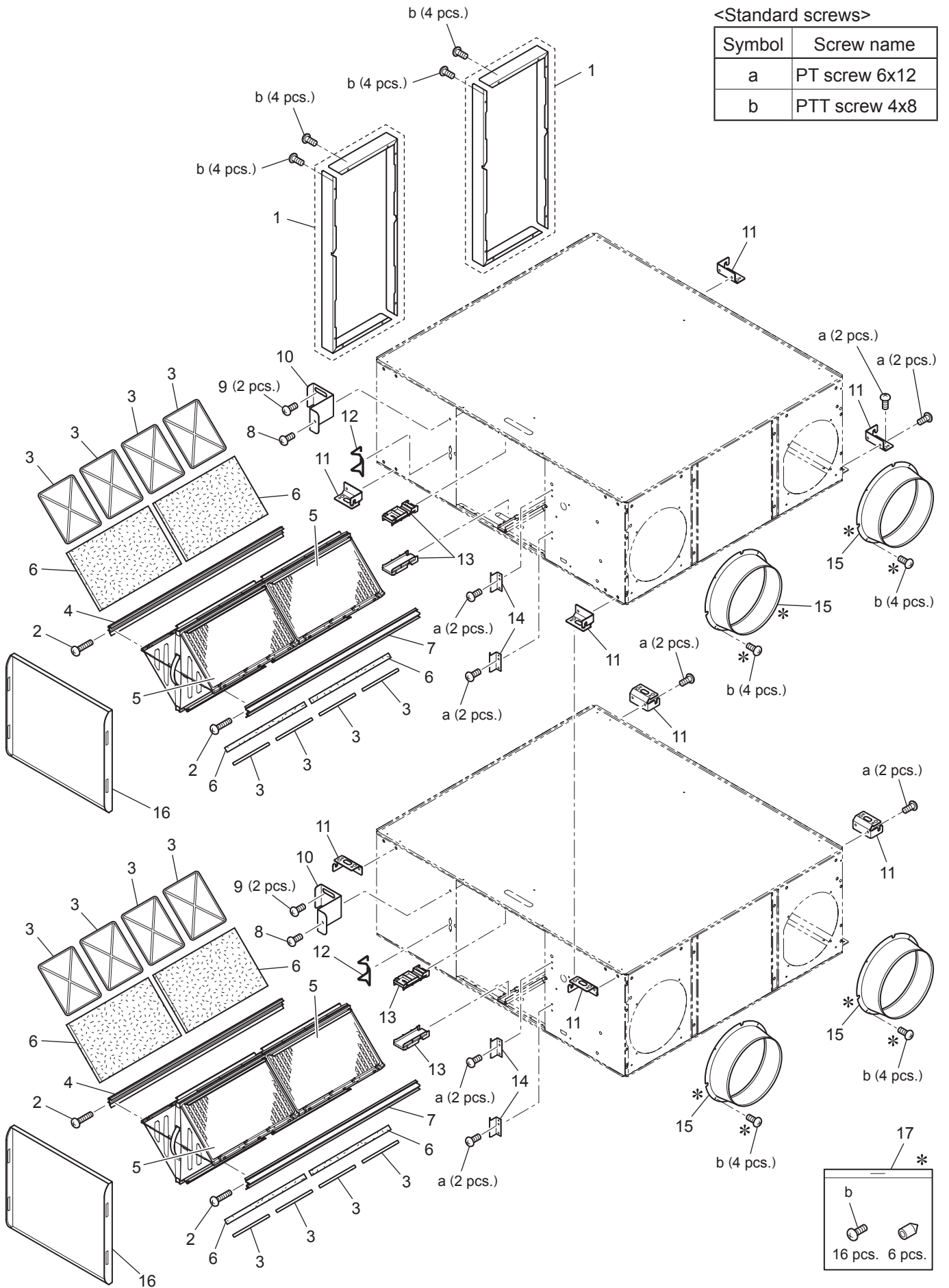

* shows accessory parts.

LGH-150RVX-E

No.	Name of part	Parts No.	Q'ty pcs/unit	Critical for safety	Remarks
1	Flange (A·B)	R50 621 704	2		
2	Spl screw M4	R50 541 045	4		
3	Filter stopper	R50 522 710	16		
4	Core guide L	R50 616 383	2		
5	Lossnay core	Y50 172 710	4	▲	With the filter stoppers
6	Filter	R50 529 717	8	▲	
7	Core guide R	R50 616 384	2		
8	Spl screw 4×8	K81 469 018	5		
9	Spl screw 4×8	Y50 169 045	4		
10	Fix piece	Y50 169 707	2		
11	Hanger	R50 111 381	8		
12	Hinge	R50 466 344	2		
13	Lead support	R50 616 704	4		
14	Fix piece	R50 614 712	4		
15	Flange	Y50 021 609	4		With a cushion
16	Maint. cover	R50 616 709	2		With cushions
17	Parts in bag	Y50 173 049	1		

Air exhaust fan assembly

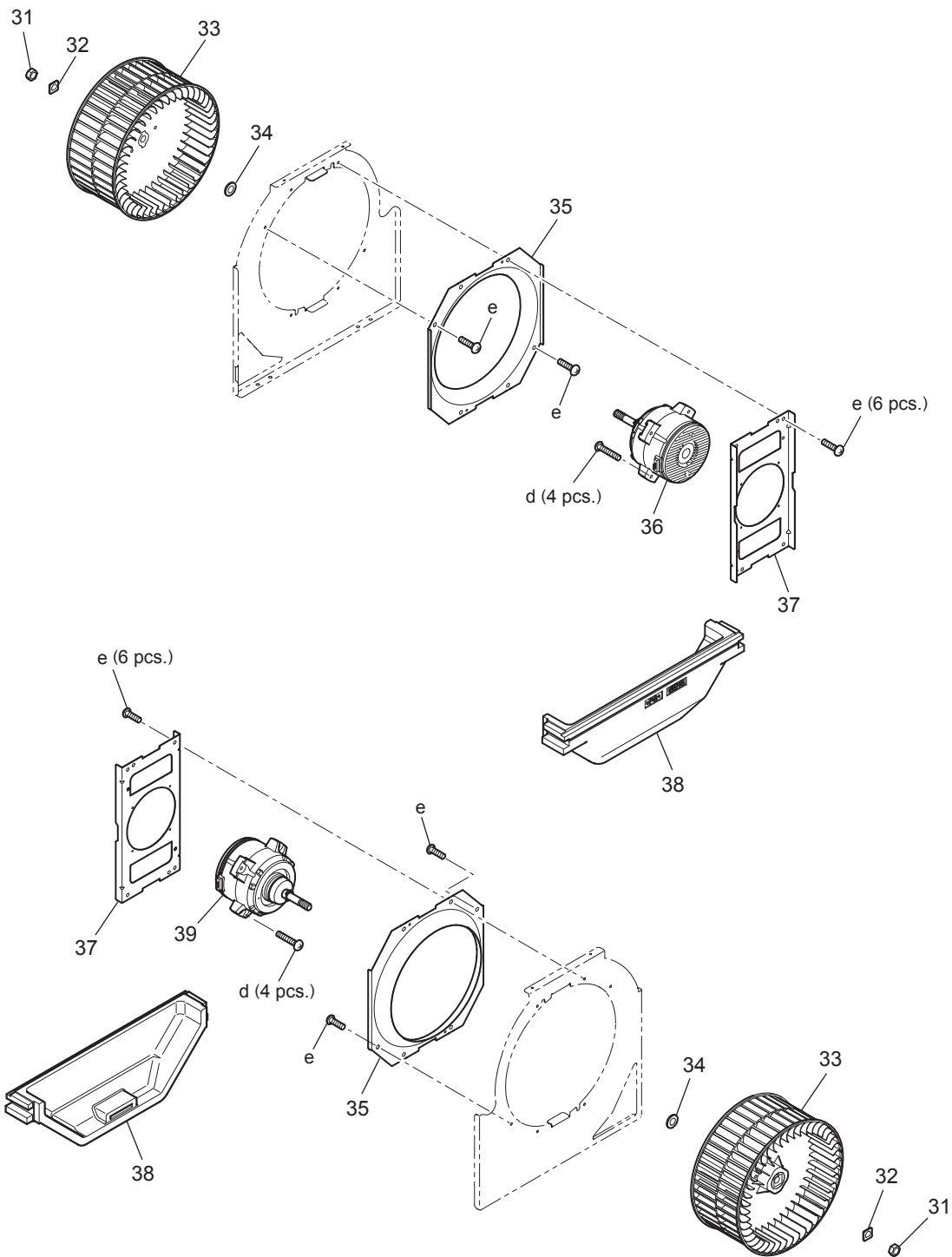

<Standard screws>

Symbol	Screw name
d	PTT screw 4x25
e	PTT screw 5x10

Air supply fan assembly

LGH-150RVX-E

No.	Name of part	Parts No.	Q'ty pcs/unit	Critical for safety	Remarks
31	Spl nut (12)	R50 218 067	4		Left-handed φ 245
32	Tab washer	Y50 171 707	4		
33	Centrifugal fan	Y50 171 480	4	⚠	
34	Washer (12)	K83 466 113	4		
35	Inlet ring	R50 543 708	4		
36	Motor	Y50 172 454	2	⚠	
37	Motor fix plate	Y50 171 712	4		
38	Separator	R50 616 486	4		
39	Motor	Y50 172 453	2	⚠	

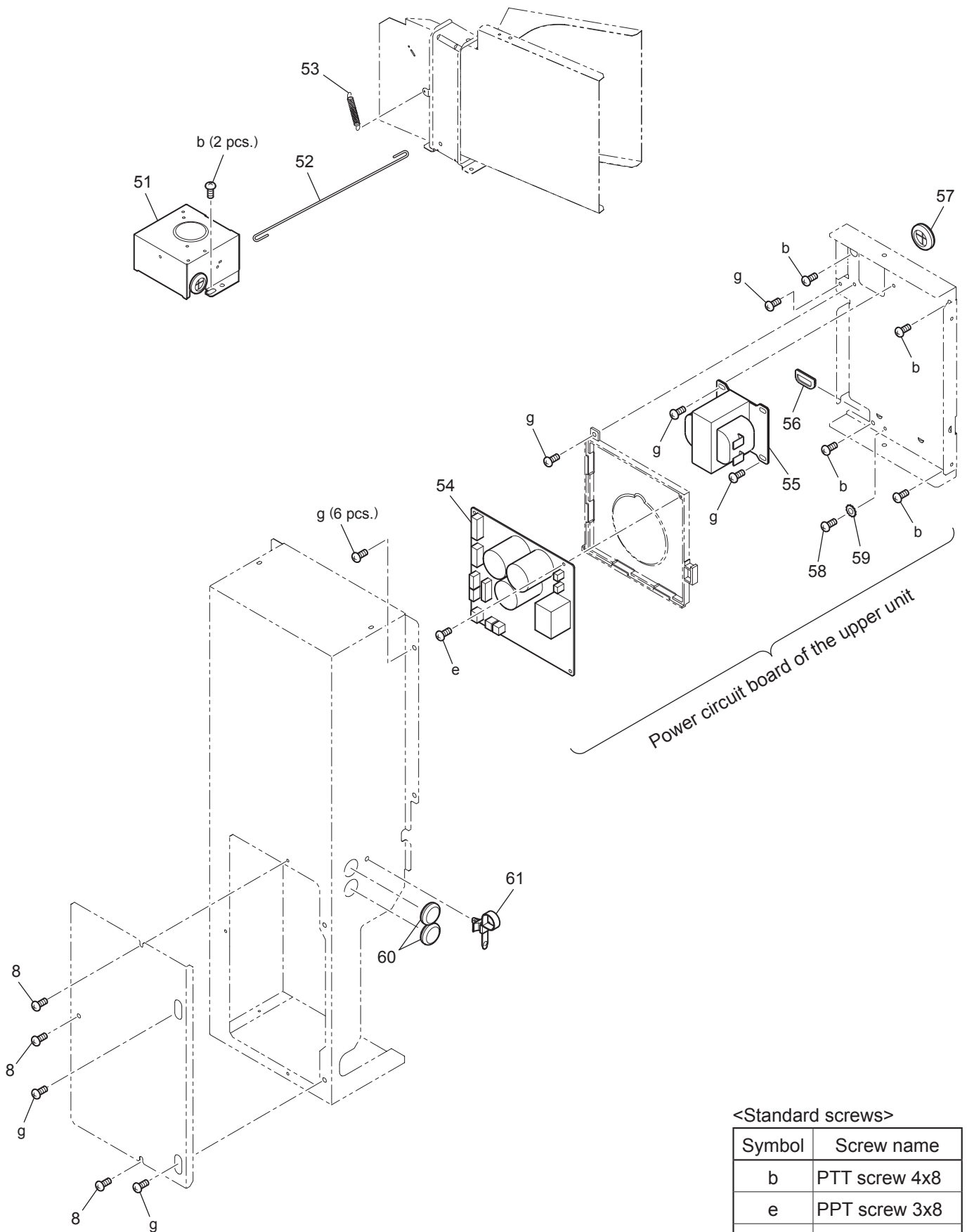

<Standard screws>

Symbol	Screw name
b	PTT screw 4x8
e	PPT screw 3x8
g	PT screw 4x8

LGH-150RVX-E

No.	Name of part	Parts No.	Q'ty pcs/unit	Critical for safety	Remarks
51	GM assy	Y50 172 260	2	⚠	AC220·240V LG-X05DC-E1
52	Rod	R50 543 150	2		
53	Pull spring	R50 637 156	2		
54	Circuit board	Y50 173 171	1	⚠	
55	Reactor	Y50 172 179	2	⚠	
56	Bush	R50 541 225	2		
57	Bush	R50 476 225	2		
58	PT screw 4×8 BS	H00 011 008	3		
59	Lock washer (4)	H00 013 076	3		
60	Bush	K83 223 225	3		
61	Cord band	Y55 001 223	1		

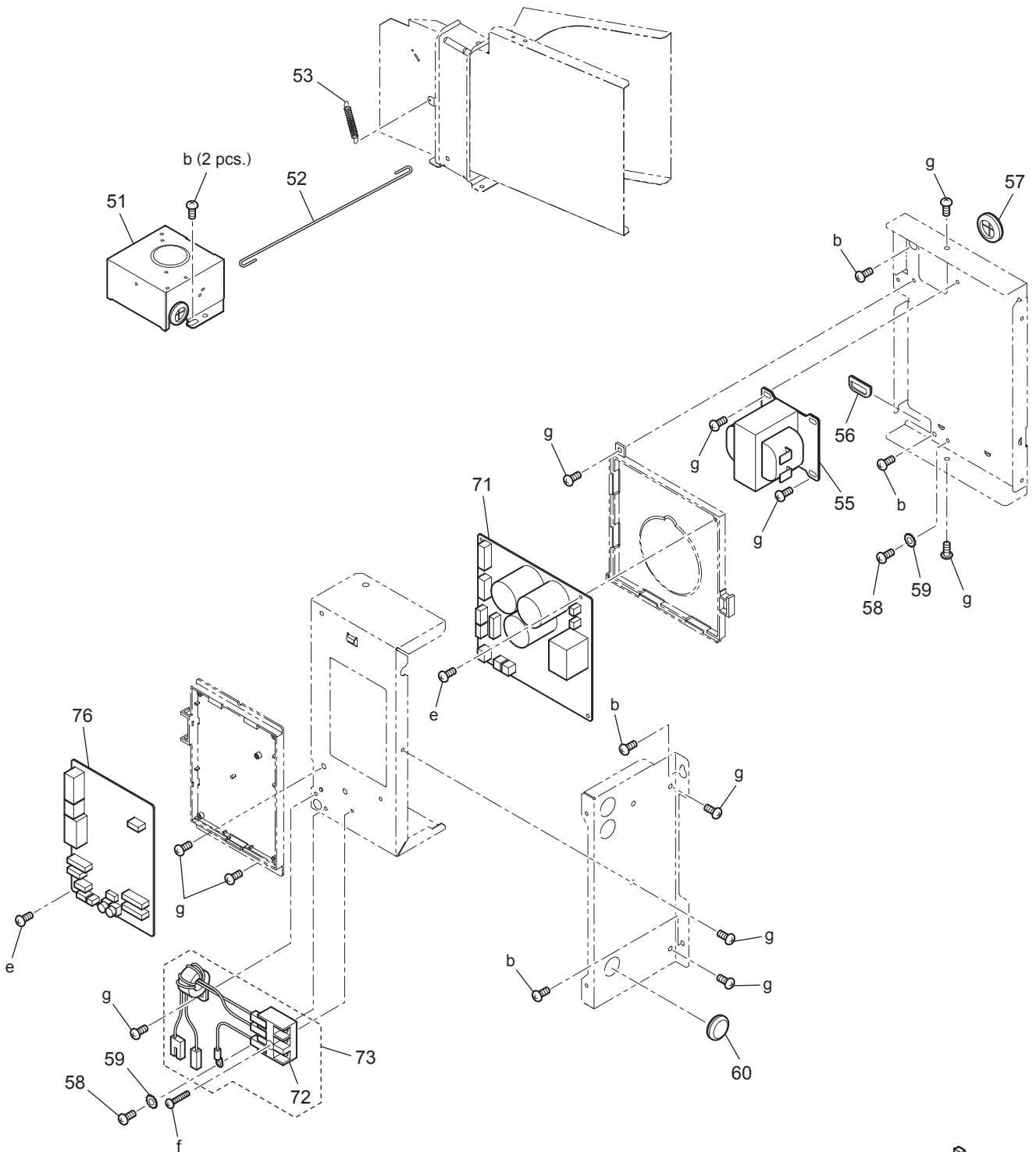

<Standard screws>

Symbol	Screw name
b	PTT screw 4x8
e	PPT screw 3x8
f	PPT screw 4x20
g	PT screw 4x8

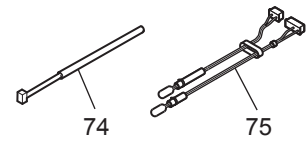

LGH-150RVX-E

No.	Name of part	Parts No.	Q'ty pcs/unit	Critical for safety	Remarks
71	Circuit board	Y50 169 172	1	▲	LG-X05DC-E·P
72	Terminal block	Y45 631 242	1	▲	3P
73	Lead wire	Y50 173 213	1	▲	With the terminal block
74	Lead wire	Y50 047 231	1	▲	100mm
75	Thermistor	Y50 170 168	1	▲	-30°C to 100°C
76	Circuit board	Y50 169 173	1	▲	LG-X05DC-E·C

LGH-200RVX-E

<Standard screws>

Symbol	Screw name
a	PT screw 6x12
b	PTT screw 4x8

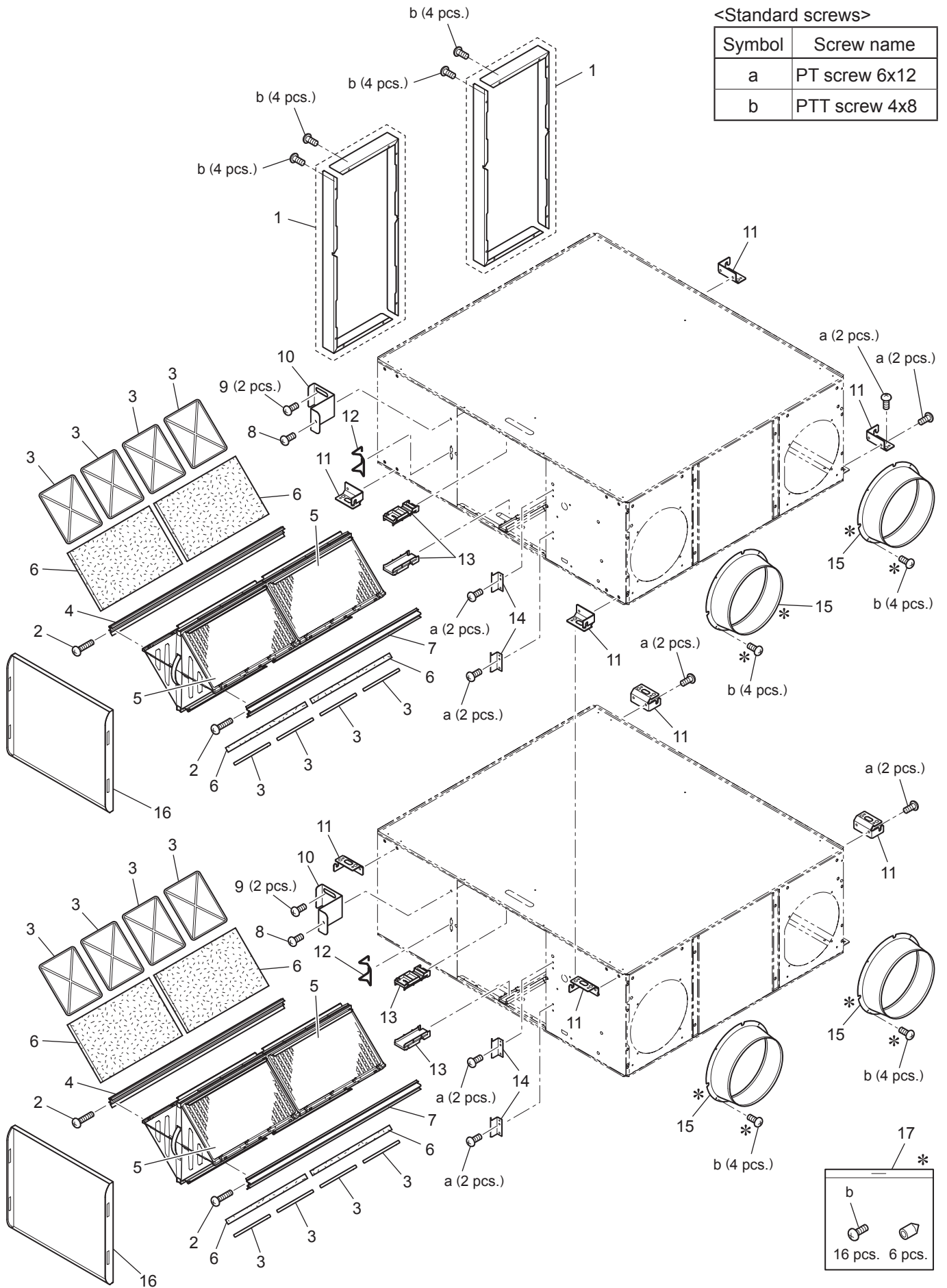

* shows accessory parts.

LGH-200RVX-E

No.	Name of part	Parts No.	Q'ty pcs/unit	Critical for safety	Remarks
1	Flange (A·B)	R50 621 704	2		
2	Spl screw M4	R50 541 045	4		
3	Filter stopper	R50 522 710	16		
4	Core guide L	R50 617 381	2		
5	Lossnay core	Y50 172 711	4	▲	With the filter stoppers
6	Filter	R50 522 717	8	▲	
7	Core guide R	R50 617 382	2		
8	Spl screw 4×8	K81 469 018	5		
9	Spl screw 4×8	Y50 169 045	4		
10	Fix piece	Y50 169 707	2		
11	Hanger	R50 111 381	8		
12	Hinge	R50 466 344	2		
13	Lead support	R50 616 704	4		
14	Fix piece	R50 614 712	4		
15	Flange	Y50 021 609	4		With a cushion
16	Maint. cover	R50 616 709	2		With cushions
17	Parts in bag	Y50 173 049	1		

Air exhaust fan assembly

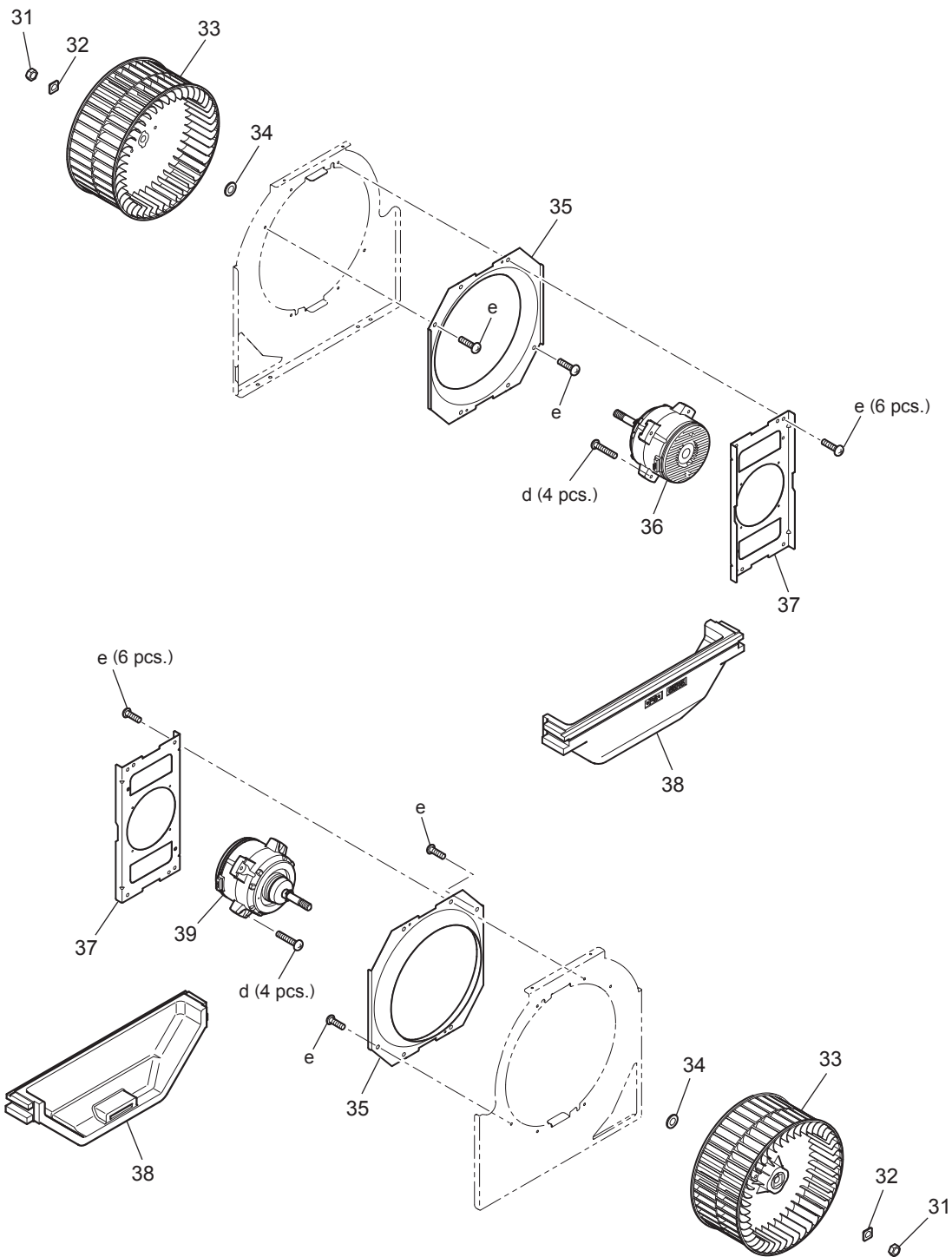

<Standard screws>

Symbol	Screw name
d	PTT screw 4x25
e	PTT screw 5x10

Air supply fan assembly

LGH-200RVX-E

No.	Name of part	Parts No.	Q'ty pcs/unit	Critical for safety	Remarks
31	Spl nut (12)	R50 218 067	4		Left-handed φ 245
32	Tab washer	Y50 171 707	4		
33	Centrifugal fan	Y50 171 480	4	⚠	
34	Washer (12)	K83 466 113	4		
35	Inlet ring	R50 543 708	4		
36	Motor	Y50 172 454	2	⚠	
37	Motor fix plate	Y50 171 712	4		
38	Separator	R50 616 486	4		
39	Motor	Y50 172 453	2	⚠	

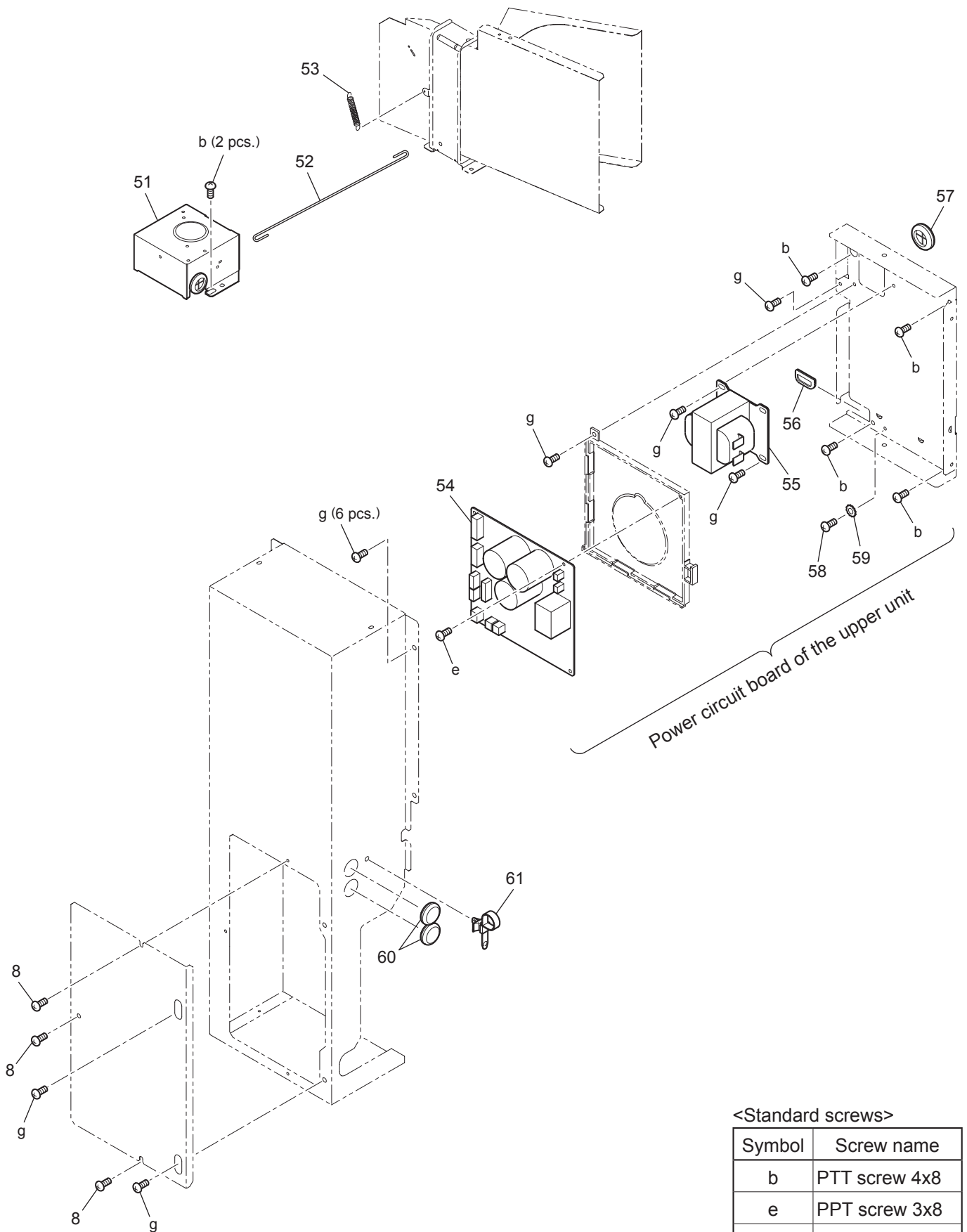

<Standard screws>

Symbol	Screw name
b	PTT screw 4x8
e	PPT screw 3x8
g	PT screw 4x8

LGH-200RVX-E

No.	Name of part	Parts No.	Q'ty pcs/unit	Critical for safety	Remarks
51	GM assy	Y50 172 261	2	⚠	AC220·240V LG-X05DC-E1
52	Rod	R50 543 150	2		
53	Pull spring	R50 637 156	2		
54	Circuit board	Y50 173 171	1	⚠	
55	Reactor	Y50 172 179	2	⚠	
56	Bush	R50 541 225	2		
57	Bush	R50 476 225	2		
58	PT screw 4×8 BS	H00 011 008	3		
59	Lock washer (4)	H00 013 076	3		
60	Bush	K83 223 225	3		
61	Cord band	Y55 001 223	1		

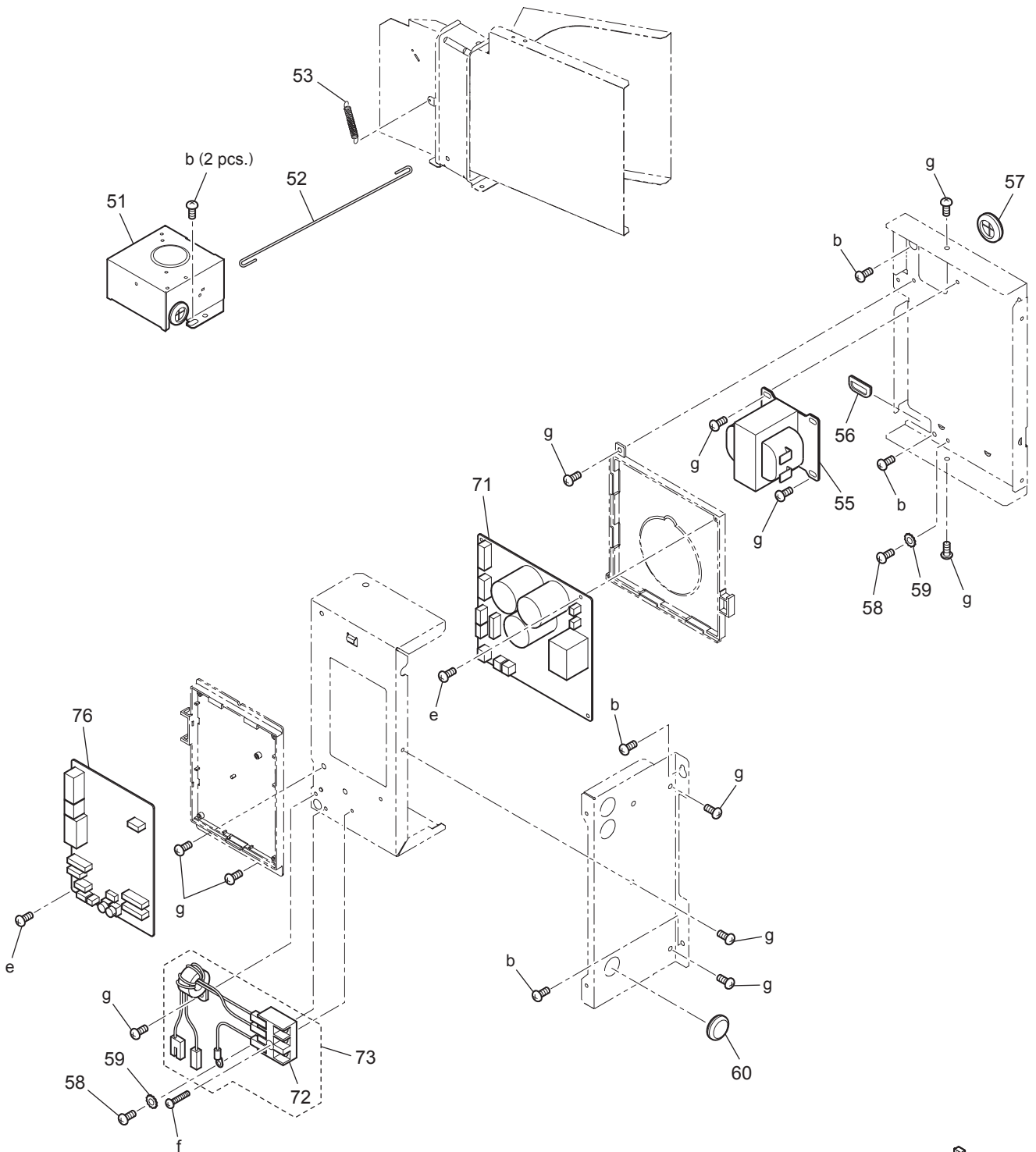

<Standard screws>

Symbol	Screw name
b	PTT screw 4x8
e	PPT screw 3x8
f	PPT screw 4x20
g	PT screw 4x8

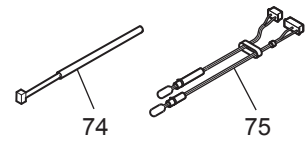

LGH-200RVX-E

No.	Name of part	Parts No.	Q'ty pcs/unit	Critical for safety	Remarks
71	Circuit board	Y50 169 172	1	▲	LG-X05DC-E·P
72	Terminal block	Y45 631 242	1	▲	3P
73	Lead wire	Y50 173 213	1	▲	With the terminal block
74	Lead wire	Y50 047 231	1	▲	100mm
75	Thermistor	Y50 172 167	1	▲	-30°C to 100°C
76	Circuit board	Y50 169 173	1	▲	LG-X05DC-E·C